

- NOTES:
- ALL DRAWINGS ARE IN METRIC MEASUREMENTS
 - ALL ENGINEERING PRACTICES SHALL BE APPLIED WITH REGARDS TO HOLE AND SHAFT TOLERANCES.
 - WHERE SCREWS OR BOLTS ARE USED THE CLEARANCE HOLES SHALL BE APPROXIMATELY 5% TO 8% LARGER THAN THE MATCHING TAPPED HOLE.
 - PREFERABLY ALL TAPPED HOLES AND MATCHING SCREWS AND/OR BOLTS TO BE METRIC FINE (MF)
 - MATERIALS SPECIFIED ON THE DRAWINGS ARE INDICATIVE ONLY. THE BUILDER CAN MAKE HIS/HER OWN MATERIAL CHOICE.
 - ALL CONNECTIONS/JOINTS WHICH HAVE STEAM PRESSURE APPLIED TO IT SHALL BE SILVER/HARD SOLDERED.
 - COMPRESSION SPRINGS ARE DRAWN IN COMPRESSED STATE (CP), UNCOMPRESSED STATE IS APPROX 40% TO 60% LONGER THEN COMPRESSED STATE.
 - WHERE PREFERRED SCREW OR RIVETED CONNECTIONS CAN BE OMITTED AND PARTS CAN BE BONDED TOGETHER BY USING EITHER HIGH STRENGTH GLUE, EPOXY RESIN, OR SOLDER.
 - PARTS WHICH ARE DIRECTLY EXPOSED TO STEAM AND/OR WATER SHOULD BE CONSTRUCTED USING NON-FERROUS OR NON CORROSIVE MATERIAL SUCH AS BRASS, BRONZE, GUNMETAL, STAINLESS STEEL, COPPER OR MONEL.
 - THE ORDER IN WHICH THE PARTS/COMPONENTS ARE MANUFACTURED AND THE MODEL IS ASSEMBLED IS ENTIRELY LEFT TO THE BUILDER/MODEL MAKER.
 - A COLOUR SCHEME FOR THIS PROJECT IS ENTIRELY LEFT UP TO THE MODEL MAKER.
 - THE MANNER IN WHICH THE PARTS/COMPONENTS ARE MANUFACTURED IS ENTIRELY LEFT UP TO THE BUILDER.
 - USE LOCTITE, ON SCREW OR PRESS FIT CONNECTIONS OR SURFACES, WERE DEEMED NECESSARY TO PREVENT PARTS FROM LOOSENING.
 - WASHERS AND/OR SPRINGWASHERS SHALL BE USED WHERE DEEMED NECESSARY.
 - N/A
 - XX. ERRORS AND/OR OMISSIONS MAY OCCUR IN THE DRAWINGS, DO NOT HESITATE TO CONTACT ME SO THAT THE ERRORS/OMISSIONS CAN BE RECTIFIED.

MATERIAL ABBREVIATIONS:

- ALU = ALUMINIUM
 - HALU= HARD ALUMINIUM
 - BRS = BRASS
 - BRZ = BRONZE OR GUNMETAL (BRZ/GM)
 - CI = CAST IRON
 - CU = COPPER
 - GRA = GRAPHITE
 - MS = MILD STEEL/BRIGHT MILD STEEL
 - SS = SILVER STEEL OR STAINLESS STEEL
 - SPS = SPRING STEEL
 - PEEK= POLYETHER ETHER KETONE
 - SYN = SYNTHETIC MATERIAL SUCH AS VETON, NYLON, TEFLON OR RUBBER
- IN GENERAL SYNTHETIC MATERIALS SHOULD BE ABLE TO WITHSTAND THE HEAT AND PRESSURE(S) APPLIED TO THEM.

nnn/nnn MEANS THAT EITHER MATERIAL CAN BE USED

OTHER ABBREVIATIONS

- DP = DEEP
- DAA= DRILL AFTER ASSEMBLY
- D&TAA= DRILL AND TAP AFTER ASSEMBLY
- CF = CLOSE FIT (SIZE FOR SIZE)
- PF = PRESS FIT
- PFAA= PRESS FIT AFTER ASSEMBLY
- PCD = PITCH CIRCLE DIAMETER
- RM = REAM
- HEX = HEXACON, 6SIDED
- CP = COMPRESSED
- KNL = KNURLED
- CSK = COUNTERSINK
- PL = PLACES
- DWL= DOWEL
- SPF= SPOTFACE
- (T)HESOP=(TAPPED)HOLES EQUALLY SPACED ON PCD
- (T)HESOC=(TAPPED)HOLES EQUALLY SPACED ON CIRCUMFERENCE
- [SA-xxx]= SUB ASSEMBLY-xxx

ADDITIONAL NOTE:

NO MATERIALS WILL BE SPECIFIED ON THESE DRAWINGS
 IF THIS ENGINE IS BUILT TO RUN ON AIR ONLY THAN ANY TYPE OF MILD STEEL AND/OR HARD ALUMINIUM COULD BE USED, SOME BRONZE OR BRASS FOR BUSHINGS AND VALVE.
 IF THIS ENGINE IS RUNNING ON STEAM THAN A COMBINATION OF DIFFERENT TYPE OF NON FERROUS/CORROSIVE MATERIALS SHOULD BE USED. REFER TO NOTE 8 ABOVE

QTY.	PART NUMBER
1	ROOT-1-01-CYLINDER BODY
1	ROOT-1-02-PORT BLOCK
1	ROOT-1-03-VALVE CHAMBER COVER
1	ROOT-2-01-LARGE PISTON
1	ROOT-2-02-SMALL PISTON
1	ROOT-2-03-CRANK SHAFT
1	ROOT-2-04-VALVE SHAFT
1	ROOT-2-05-VALVE
1	ROOT-2-06-FLYWHEEL
4	ROOT-M3x3 A-K GRUB SCREW
1	ROOT-M3x5 A-K GRUB SCREW
8	ROOT-M4x14 A-K CYL HEAD SCREW
12	ROOT-M4x36 A-K CYL HEAD SCREW

NOTES: THIS DESIGN IS BASED ON TWO SETS OF DRAWINGS WHICH WERE GIVEN TO ME. THE ORIGINAL DRAWINGS AND ARTICLE WERE PUBLISHED IN A UNSPECIFIED MAGAZINE (PAGES 23 TO 25) UNDER THE TITLE "AN HISTORICAL REVIVAL IN MINIATURE ROOT'S ENGINE" BY ROBERT S HEDIN. THE SECOND SET OF DRAWINGS WERE BY E. WEINBERG

TITLE
A RECTANGULAR CYLINDER STEAM/AIR ENGINE DESIGN BY J. B. ROOT (ca 1864)

DRAWING CONTENTS
GENERAL ARRANGEMENT, NOTES, BILL OF MATERIALS

PROJECT No 09E-28-00
 JDW DRAUGHTING SERVICES
 J.A.M. DE WAAL, 12 BRIGHTWELL STREET PAPAURA 2110. NEW ZEALAND. PHONE: 0064 09 2988815. MOB: 0211791000 E-MAIL: dewaal@xtra.co.nz.

PROJECTION
JDWDS
 DATE: AUGUST 2018
 SHEET: 01 OF 02
 MODEL SCALE: 1:1
 DWG SCALE: NTS @A3 OR AS SHOWN
 Copyright © J.A.M. DE WAAL PAPAURA NZ
A3 No: 09E-28-00-SHT01

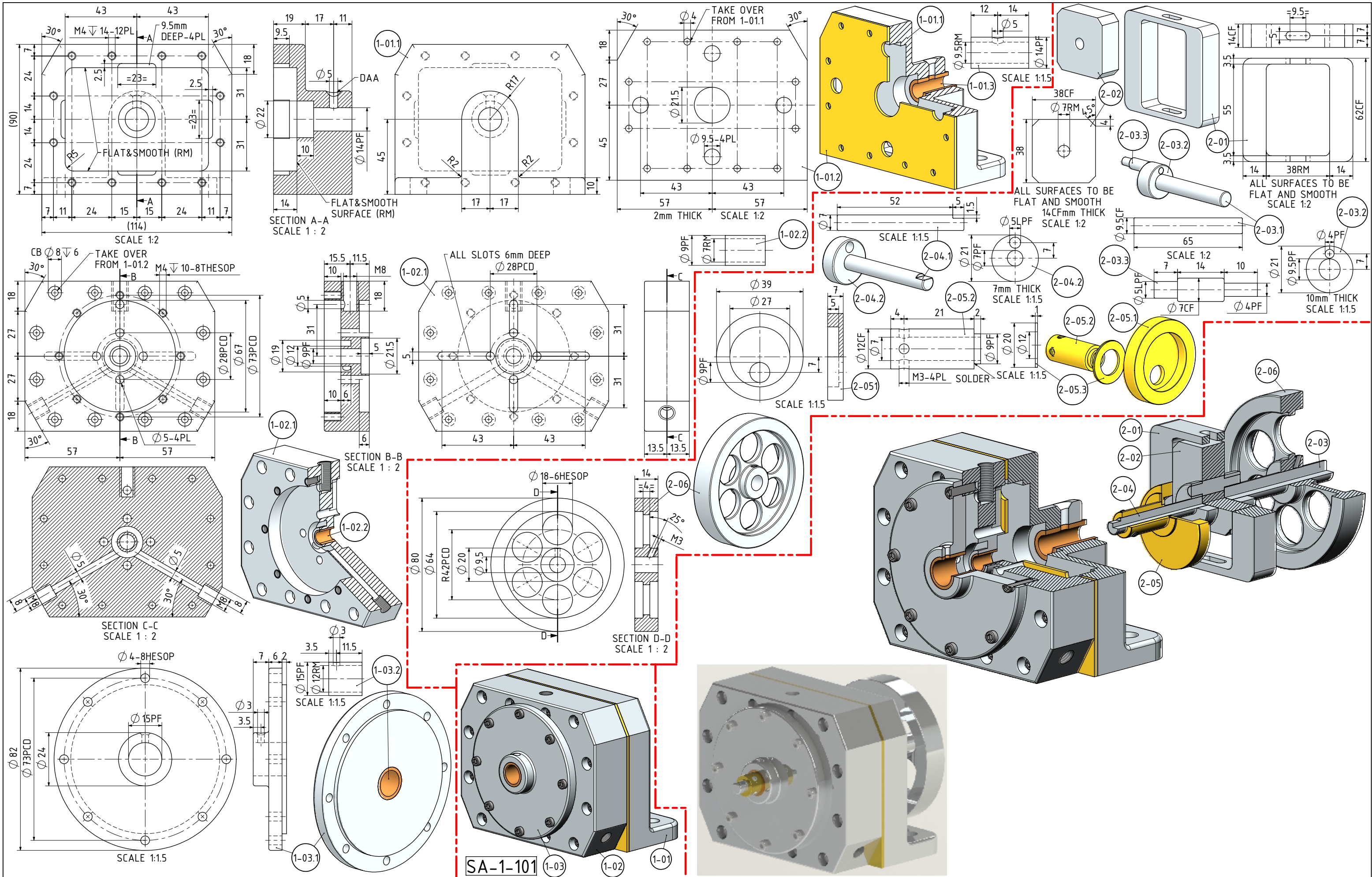

NOTES: THIS DESIGN IS BASED ON TWO SETS OF DRAWINGS WHICH WERE GIVEN TO ME. THE ORIGINAL DRAWINGS AND ARTICLE WERE PUBLISHED IN A UNSPECIFIED MAGAZINE (PAGES 23 TO 25) UNDER THE TITLE "AN HISTORICAL REVIVAL IN MINIATURE ROOT'S ENGINE" BY ROBERT S HEDIN. THE SECOND SET OF DRAWINGS WERE BY E. WEINBERG

TITLE
A RECTANGULAR CYLINDER STEAM/AIR ENGINE DESIGN BY J. B. ROOT (ca 1864)

DRAWING CONTENTS
PARTS AND ASSEMBLIES

PROJECT No 09E-28-00
 JDW DRAUGHTING SERVICES
 J.A.M. DE WAAL, 12 BRIGHTWELL STREET PAPAURA 2110.
 NEW ZEALAND. PHONE: 0064 09 2988815. MOB: 0211791000
 E-MAIL: dewaal@xtra.co.nz.

PROJECTION 	DATE AUGUST 2018	MODEL SCALE: 1:1 DWG SCALE: 1:1 @A3 OR AS SHOWN Copyright © J.A.M. DE WAAL PAPAURA NZ
SHEET: 02 OF 02	A3	No: 09E-28-00-SHT02