

QTY.	PART NUMBER
1	REBI-01-BASE PLATE
1	REBI-02-CYLINDER HOLDING BRACKET
2	REBI-03-CRANK SHAFT BEARING HOLDING BRACKET
1	REBI-04-CYLINDER
1	REBI-05-CYLINDER LINING
1	REBI-06-CYLINDER HEAD
2	REBI-07-BALL BEARING HOLDER
4	REBI-09-CRANK SHAFT BALL BEARING
1	REBI-10-CRANK SHAFT
1	REBI-11-PISTON
1	REBI-12-PISTON CONNECTOR
1	REBI-13-CON-ROD HEAD
1	REBI-14-CON-ROD
1	REBI-15-CON-ROD BIG END
1	REBI-16-FLY WHEEL
1	REBI-17-REAR ENCLOSURE
1	REBI-17-REAR ENCLOSURE
1	REBI-18-CAM
1	REBI-19-INLET VALVE PUSH ROD
2	REBI-20-INLET VALVE PUSH ROD SPACER
1	REBI-21-CAM FOLLOWER WHEEL
1	REBI-22-INLET VALVE
1	REBI-23-EXHAUST VALVE
1	REBI-24-EXHAUST VALVE GUIDE
1	REBI-25-INLET VALVE ROD SPRING
1	REBI-25-OIL CUP
1	REBI-26-CAM FOLLOWER WHEEL AXLE
1	REBI-27-WOOD BASE
1	REBI-28-FUEL TANK
2	REBI-M2.5x12 P-HEAD SCREW
2	REBI-M3 NUT
13	REBI-M3x0.8 WASHER
2	REBI-M3x10 P-HEAD SCREW
15	REBI-M3x12 C-SINK SCREW
2	REBI-M3x12 P-HEAD SCREW
5	REBI-M3x18 P-HEAD SCREW
2	REBI-M3x25 P-HEAD SCREW
1	REBI-M3x5 P-HEAD SCREW
1	REBI-M3x6 GRUB SCREW
1	REBI-M4x12 P-HEAD SCREW
4	REBI-M6 WASHER
2	REBI-WOOD SCREW 4x15

NOTES:
 TITLE
 AIR-COOLED VACUUM ENGINE CALLED "REBI"
 (MODIFIED)

DRAWING CONTENTS
 GENARAL ARRANGEMENT, ISOMETRIC
 VIEWS AND BILL OF MATERIAL

PROJECT No
 JDW DRAUGHTING SERVICES
 J.A.M. DE WAAL, 12 BRIGHTWELL STREET PAPAURA 2110.
 NEW ZEALAND. PHONE: 0064 09 2988815. MOB: 0211791000
 E-MAIL: dewaal@xtra.co.nz.

PROJECTION

 DATE
 AUGUST-2013
 SHEET:01 OF 02

MODEL SCALE: 1:1
 DWG SCALE: 1:1 @A3 OR AS SHOWN
 Copyright © J.A.M. DE WAAL PAPAURA NZ
 A3 No: REBI-01

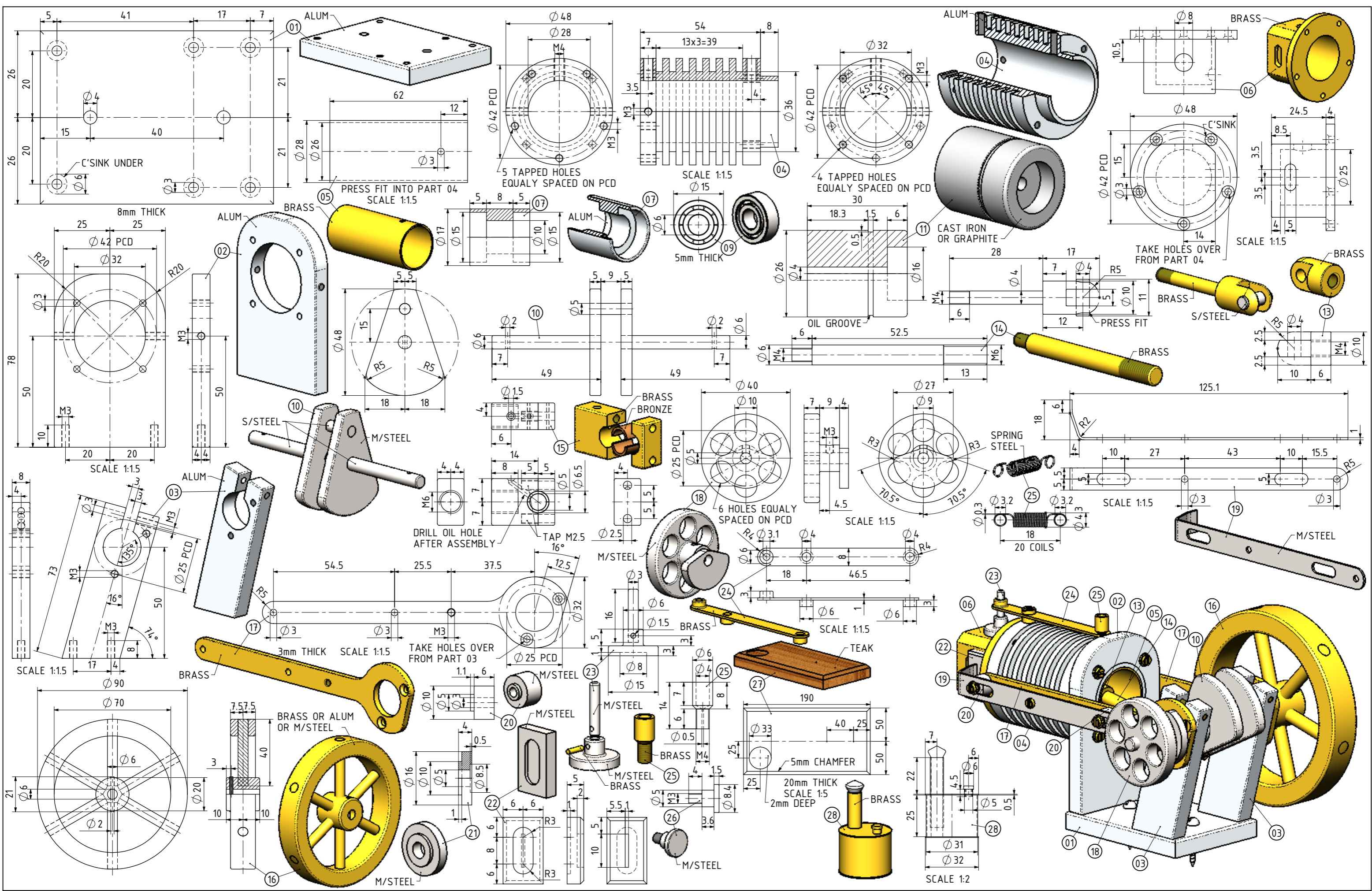

NOTES:
 TITLE
AIR-COOLED VACUUM ENGINE CALLED "REBI" (MODIFIED)

DRAWING CONTENTS
PARTS AND ASSEMBLIES

PROJECT No
JDW DRAUGHTING SERVICES
 J.A.M. DE WAAL, 12 BRIGHTWELL STREET PAPAOKURA 2110.
 NEW ZEALAND. PHONE: 0064 09 2988815. MOB: 0211791000
 E-MAIL: dewaal@xtra.co.nz.

PROJECTION
 DATE
AUGUST-2013
 SHEET:02 OF 02

MODEL SCALE: 1:1
 DWG SCALE: 1:1 @A3 OR AS SHOWN
 Copyright © J.A.M. DE WAAL PAPAOKURA NZ
A3 No: REBI-02