

QTY.	PART NUMBER
1	POPPIN-01-BASE PLATE
1	POPPIN-02-STANDARD
1	POPPIN-03-CYLINDER
1	POPPIN-04-CYLINDER FRONT LID
1	POPPIN-05-OIL CUP
2	POPPIN-06A-CRANK SHAFT BEARING
2	POPPIN-06B-VALVE SHAFT BEARING
2	POPPIN-07-BEARING SPACER
1	POPPIN-08-CRANK SHAFT
2	POPPIN-09-FLYWHEEL
2	POPPIN-10-FLYWHEEL HUB
2	POPPIN-11-CAM WASHER
2	POPPIN-12-FLYWHEEL NUT
1	POPPIN-13-CAM
1	POPPIN-14-PISTON
1	POPPIN-15-PISTON YOKE
1	POPPIN-16-CON-ROD
1	POPPIN-17-VALVE SHAFT
1	POPPIN-18-VALVE ROCKER ARM
1	POPPIN-19-VALVE ROD
1	POPPIN-20-CAM FOLLOWER ROLLER
1	POPPIN-21-ROLLER SHAFT
1	POPPIN-22-VALVE
1	POPPIN-23-VALVE SPRING
1	POPPIN-24-FUEL TANK
1	POPPIN-25-WOODEN STAND
3	POPPIN-M1.5 NUT
2	POPPIN-M1.5x10 P-HEAD SCREW
1	POPPIN-M1.5x8 P-HEAD SCREW
2	POPPIN-M2 NUT
3	POPPIN-M2 WASHER
1	POPPIN-M2.5x4 P-HEAD SCREW
2	POPPIN-M2.5x5 GRUB SCREW
4	POPPIN-M2x10 P-HEAD SCREW
4	POPPIN-M2x12 C-SINK SCREW
4	POPPIN-M2x5 P-HEAD SCREW
1	POPPIN-RIVET 1.5x5
4	POPPIN-WOOD SCREW 3x12

NOTES:
 TITLE
 AIR-COOLED VACUUM ENGINE CALLED "POPPIN"
 BY Dr.J.R.SENFT (MAGAZINE: LIVE STEAM 1980)

DRAWING CONTENTS
 GENERAL ARRANGEMENT, ISOMETRIC
 VIEWS AND BILL OF MATERIAL

PROJECT No
 JDW DRAUGHTING SERVICES
 J.A.M. DE WAAL, 12 BRIGHTWELL STREET PAPAURA 2110.
 NEW ZEALAND. PHONE: 0064 09 2988815. MOB: 0211791000
 E-MAIL: dewaal@xtra.co.nz.

PROJECTION
 DATE
 AUGUST-2013
 SHEET:01 OF 02

MODEL SCALE: 1:1
 DWG SCALE: 1:1 @A3 OR AS SHOWN
 Copyright © J.A.M. DE WAAL PAPAURA NZ
 A3 No: POPPIN-01

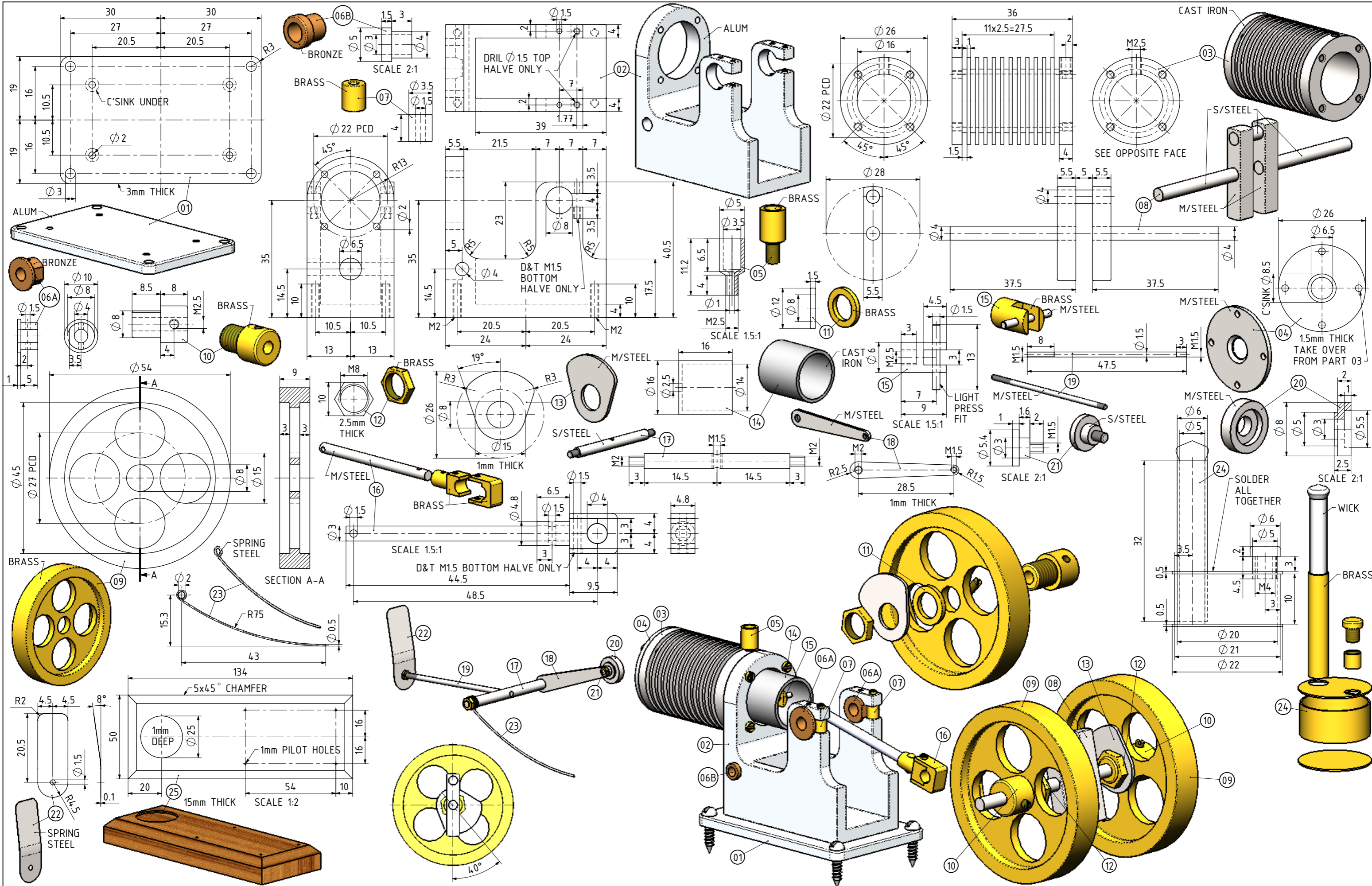

NOTES:
 TITLE
AIR-COOLED VACUUM ENGINE CALLED "POPPIN"
BY Dr.J.R.SENFT (MAGAZINE: LIVE STEAM 1980)

DRAWING CONTENTS
PARTS AND ASSEMBLIES

PROJECT No
JDW DRAUGHTING SERVICES
 J.A.M. DE WAAL, 12 BRIGHTWELL STREET PAPAOKURA 2110.
 NEW ZEALAND. PHONE: 0064 09 2988815. MOB: 0211791000
 E-MAIL: dewaal@xtra.co.nz.

PROJECTION
 DATE
AUGUST-2013
 SHEET:02 OF 02

MODEL SCALE: 1:1
 DWG SCALE: 1:1 @A3 OR AS SHOWN
 Copyright © J.A.M. DE WAAL PAPAOKURA NZ
A3 No: POPPIN-02