

QTY.	PART NUMBER
2	CLASSN-01-BUFFER BEAM
2	CLASSN-02-SIDE BEAM
2	CLASSN-03-CENTER CROSS BEAM
12	CLASSN-04-ANGLE MOUNTING BRACKET
2	CLASSN-05-INNER SUPPORT BEAM
2	CLASSN-06-INNER CROSS SUPPORT BEAM
2	CLASSN-07-INNER PULL STAY
2	CLASSN-08-BUFFER COUPLING
4	CLASSN-09-INNER BUFFER BEAM STAY
2	CLASSN-10-INNER BUFFER STEM RETAINER ROD
2	CLASSN-11-RETAINER ROD MOUNTING PLATE
2	CLASSN-12-BUFFER BACK PLATE
4	CLASSN-13-CHAIN HANGER BRACKET
4	CLASSN-14-AXLE BOX SHEEN PLATE
4	CLASSN-15-AXLE BOX
4	CLASSN-16-AXLE BOX SPRING BOX HOLDER
1	CLASSN-17-BRAKE SHAFT INNER END BRACKET
1	CLASSN-18-BRAKE SHOE
2	CLASSN-19-BRAKE SHOE LEVER
1	CLASSN-20-BRAKE SHAFT OUTER END BRACKET
1	CLASSN-21-BRAKE OPERATING LEVER+SHAFT
1	CLASSN-22-BRAKE LEVER TOP BRACKET
1	CLASSN-23-BRAKE LEVER
1	CLASSN-24-BRAKE LEVER TOP BRACKET SHORT
1	CLASSN-25-BRAKE HANDLE REST
4	CLASSN-26-CHAIN+HOOK
1	CLASSN-27-TIMBER TOP DECK
1	CLASSN-28-BOLSTER
2	CLASSN-29-BOLSTER UPRIGHT
2	CLASSN-30-BOLSTER TIE STYRUP
1	CLASSN-RAIL-45mm
2	CLASSN-SPOKED LGB WHEEL SET

NOTES:

TITLE
NZR CLASS N 11F† 4-WHEEL TIMBER WAGON

DRAWING CONTENTS
GENERAL ARRANGEMENT

PROJECT No
JDW DRAUGHTING SERVICES
 J.A.M. DE WAAL, 12 BRIGHTWELL STREET PAPA KURA 2110.
 NEW ZEALAND. PHONE: 0064 09 2988815. MOB: 0211791000
 E-MAIL: dewaal@xtra.co.nz.

PROJECTION
JDWDS MODEL SCALE: 1:24
 DATE FEBRUARY 2015 DWG SCALE: 1:1 @A3 OR AS SHOWN
 Copyright © J.A.M. DE WAAL PAPA KURA NZ
 SHEET: 01 OF 02 **A3** No: NZRCN-45-01

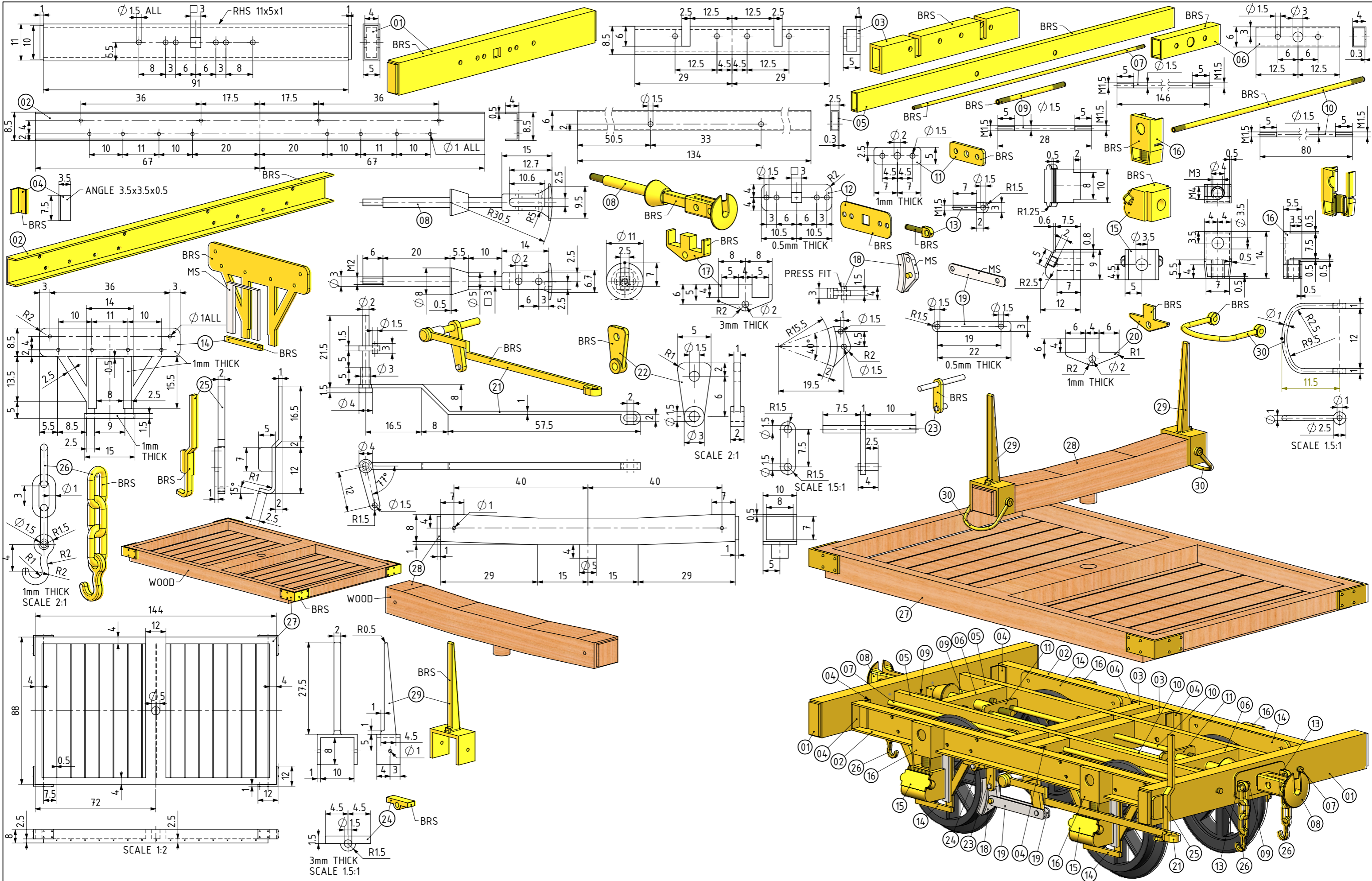

NOTES:
 TITLE
NZR CLASS N 11ft 4-WHEEL TIMBER WAGON

DRAWING CONTENTS
PARTS AND ASSEMBLIES

PROJECT No
JDW DRAUGHTING SERVICES
 J.A.M. DE WAAL, 12 BRIGHTWELL STREET PAPAOKURA 2110.
 NEW ZEALAND. PHONE: 0064 09 2988815. MOB: 0211791000
 E-MAIL: dewaal@xtra.co.nz.

PROJECTION	JDWDS	MODEL SCALE: 1:24
DATE	FEBRUARY 2015	DWG SCALE: 1:1 @A3 OR AS SHOWN
SHEET: 02 OF 02		Copyright © J.A.M. DE WAAL PAPAOKURA NZ
A3		No: NZRCN-45-02