

DESIGNED AND BUILT BY Mr W.A. VAN SCHAIK - RESOURCES "DE MODELBOUWER" 8, 9, 10/2000 & 1/2001 -

A3	TITLE	STEAM ROLLER WITH OSCILLATING ENGINE
		GENERAL ARRANGEMENT

REV	DESCRIPTION	DATE
A	ISSUED FOR CONSTRUCTION	

JDW DRAUGHTING SERVICES
 12 BRIGHTWELL STREET
 PAKAKURA NEW ZEALAND
 TEL/FAX 0064-09-2988815
 E-MAIL:dewaal@xtra.co.nz

DRAWN BY
 J.A.M. DE WAAL
 DATE
 APRIL 2010

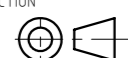
PROJECTION

 SCALE
 NTS or AS SHOWN

DRAWING NUMBER
 SR-001
 SHEET
 01 of 09
 REV
 A

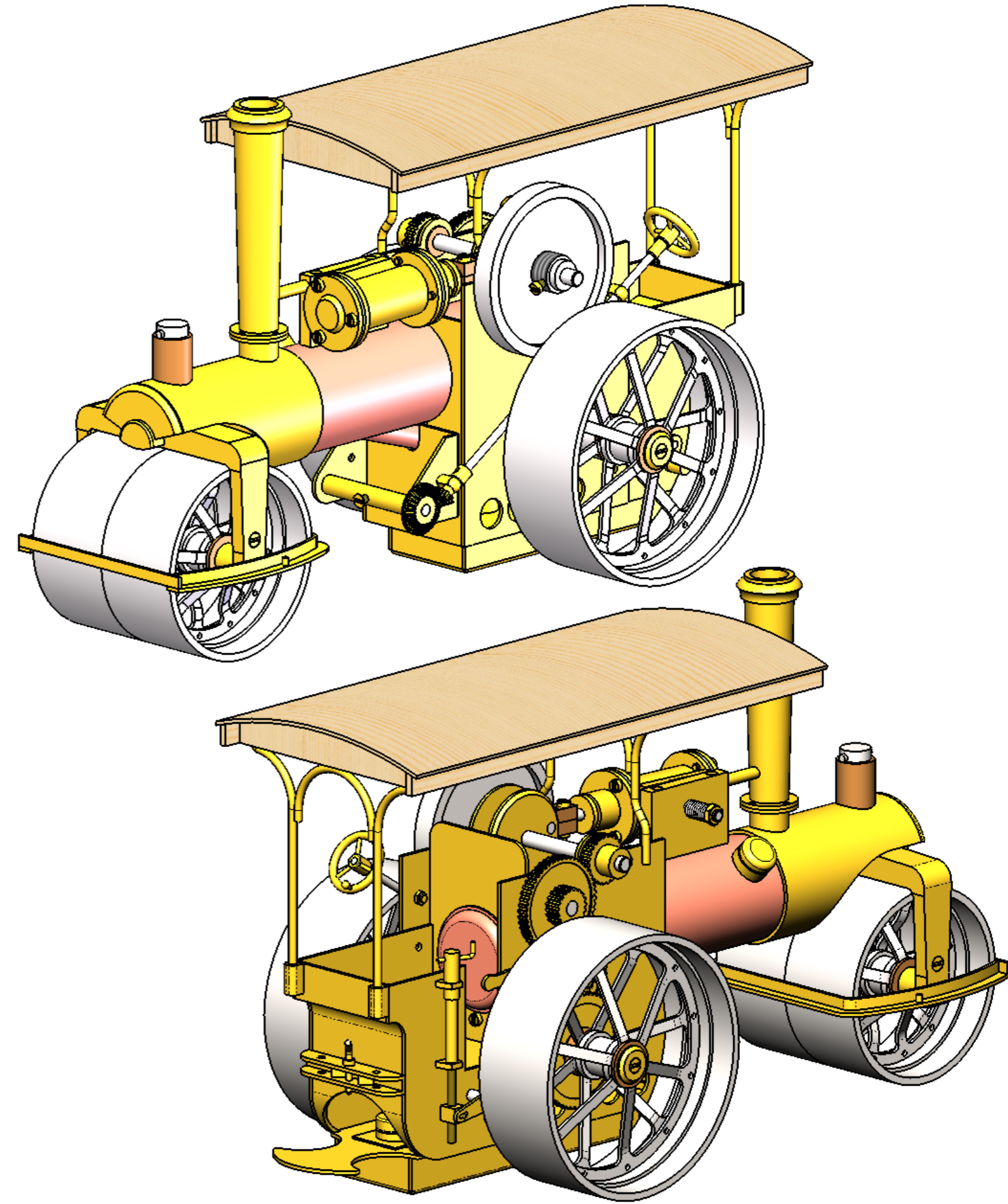
QTY.	PART NUMBER	QTY.	PART NUMBER
1	001-BOILER SHELL	2	082-FRONT WHEEL BOGIE AXLE SPACER
2	002-BOILER END	2	083-FRONT WHEEL HUB
1	003-BOILER WATER FILLER	4	084-FRONT WHEEL HUB BEARING
1	004-BOILER WATER FILLER O-RING	2	085-FRONT WHEEL OUTER RIM
1	005-BOILER WATER FILLER LID	2	086-FRONT WHEEL INNER RIM
1	006-BOILER WATER PIPE	4	087-FRONT WHEEL SPOKES
2	007-BOILER STEAM PORTS BLOCK STOP	1	088-BUNKER LEFT HAND PLATE
1	008-BOILER STEAM PORTS BLOCK	1	089-BUNKER RIGHT HAND PLATE
1	009-BOILER STEAM PORTS BLOCK EXHAUST PIPE	1	090-BUNKER REAR PLATE
1	010-BOILER END BLOCK	1	091-BUNKER DRAW BAR
1	011-CYLINDER FRONT COVER	1	092-BUNKER DRAW BAR PIN
2	012-CYLINDER TEFLON GASKET	2	093-HANDBRAKE BRACKET
1	013-CYLINDER REAR COVER	1	094-HANDBRAKE SPINDLE
1	014-CYLINDER REAR COVER GLAND	1	095-HANDBRAKE SPINDLE BUSH
1	015-CYLINDER PORTS BLOCK	1	096-HANDBRAKE SPINDLE THREAD BLOCK
1	016-CYLINDER PORTS BLOCK STUD	2	097-HANDBRAKE BRAKE PAD HOLDER
1	017-CYLINDER PORTS BLOCK SPRING	2	098-HANDBRAKE BRAKE PAD
1	018-CYLINDER	1	099-HANDBRAKE BRAKE PAD LEVER
1	019-PISTON BIG END PART-1	1	100-HANDBRAKE BRAKE AXLE
1	020-PISTON BIG END PART-2	1	101-HANDBRAKE BRAKE AXLE SPACER
1	021-PISTON	1	102-FOOT PLATE
1	022-PISTON ROD	1	103-BURNER PAN
1	023-FLYWHEEL	1	104-BURNER TOP LID
2	024-CRANK SHAFT BEARING HOLDER	3	105-BURNER WICK HOLDER
2	025-CRANK SHAFT BEARING	1	106-BURNER FILLER
2	026-CRANK CHEEK	1	107-BURNER HOLDER
1	027-CRANK PIN	1	108-BURNER FILLER LID
1	028B-CRANK SHAFT PART 2	1	109-BURNER FILLER O-RING
1	028A-CRANK SHAFT PART 1	2	110-ROOF FRONT PILLAR
1	029-FIRE BOX FRONT PLATE	2	110-ROOF REAR PILLAR
1	030-FIRE BOX REAR PLATE	2	111-ROOF PILLAR ARCH
1	031-FIRE BOX RIGHT HAND PLATE	4	112-ROOF BEAM
1	032-FIRE BOX LEFT HAND PLATE	1	113-ROOF
1	033-FIRE BOX ANGLE	2	114-ROOF SIDE BOARD
1	034-FIRE BOX LEFT HAND WHEEL AXLE	2	115-ROOF PILLAR HOLDER
1	035-FIRE BOX RIGHT HAND WHEEL AXLE	3	M4 NUT
1	036-FIRE BOX RIGHT HAND STIFFENING PLATE	8	M4x10 CYLINDERHEAD SCREW
1	037-FIRE BOX BEARING TYPE A	7	M4x12 COUNTERSINK SCREW
1	038-FIRE BOX BEARING TYPE B	1	M4x25 SPECIAL CYLINDERHEAD SCREW
2	039-FIRE BOX AXLE LOCK WASHER	2	M4x4 COUNTERSINK SCREW
1	040-GEAR WHEEL F	10	M4x5 CYLINDERHEAD SCREW
1	041-GEAR WHEEL D-E	1	M6 NUT
1	042-GEAR WHEEL D-E SHAFT		
1	043-GEAR WHEEL D-E SHAFT LOCK SPACER		
1	044-GEAR WHEEL B-C		
1	045-GEAR WHEEL B-C SHAFT		
1	046-GEAR WHEEL B-C CLUTCH		
1	047-GEAR WHEEL B-C WASHER		
1	048-GEAR WHEEL A		
1	049-STEERING BRACKET		
1	050-STEERING CHAIN TUBE		
1	051-STEERING SHAFT GEAR WHEEL A		
1	052-STEERING CHAIN SHAFT		
1	053-STEERING SHAFT GEAR WHEEL B		
1	054-STEERING SHAFT		
1	055-STEERING SHAFT GUIDE1		
1	056-STEERING SHAFT GUIDE2		
1	057-STEERING WHEEL		
1	058-STEERING SHAFT LOCKING COLLAR		
2	059-REAR WHEEL HUB		
3	060-REAR WHEEL HUB BEARING		
1	061-REAR WHEEL HUB BEARING-1		
2	062-REAR WHEEL OUTER RIM		
2	063-REAR WHEEL INNER RIM		
4	064-REAR WHEEL SPOKES		
1	065-SMOKE BOX SHELL		
1	066-SMOKE BOX CENTRE LID		
1	067-SMOKE BOX FRONT LID		
1	068-SMOKE BOX FRONT BUSH		
1	069-SMOKE STACK INNER BOTTOM PART		
1	070-SMOKE STACK INNER BOTTOM PART STOP		
1	071-SMOKE STACK INNER TOP PART		
1	072A-SMOKE STACK OUTER TOP RING		
1	072B-SMOKE STACK OUTER		
1	073-FRONT WHEEL BOGIE BEARING		
1	074-FRONT WHEEL BOGIE YOKE		
1	075-FRONT WHEEL BOGIE BEARING BUSH		
1	076-FRONT WHEEL BOGIE BEARING LOCKING PIN		
2	077-FRONT WHEEL BOGIE BEARING BUSH WASHER		
2	078-FRONT WHEEL BEARING		
1	079-FRONT WHEEL BOGIE BEARING FRAME		
1	080-FRONT WHEEL BOGIE BEARING FRAME RETAINER		
1	081-FRONT WHEEL BOGIE AXLE		



DESIGNED AND BUILT BY Mr W.A. VAN SCHAIK - RESOURCES "DE MODELBOUWER" 8, 9, 10/2000 & 1/2001 -

TITLE
STEAM ROLLER WITH OSCILLATING ENGINE
A3 GENERAL ARRANGEMENT ISOMETRIC VIEWS

JDW DRAUGHTING SERVICES 12 BRIGHTWELL STREET PAKAPURA NEW ZEALAND TEL/FAX 0064-09-2988815 E-MAIL:dewaal@xtra.co.nz		DRAWN BY J.A.M. DE WAAL	PROJECTION 	DRAWING NUMBER SR-002
A ISSUED FOR CONSTRUCTION	DATE	DATE APRIL 2010	SCALE NTS or AS SHOWN	SHEET 02 of 09
REV DESCRIPTION	DATE			REV A

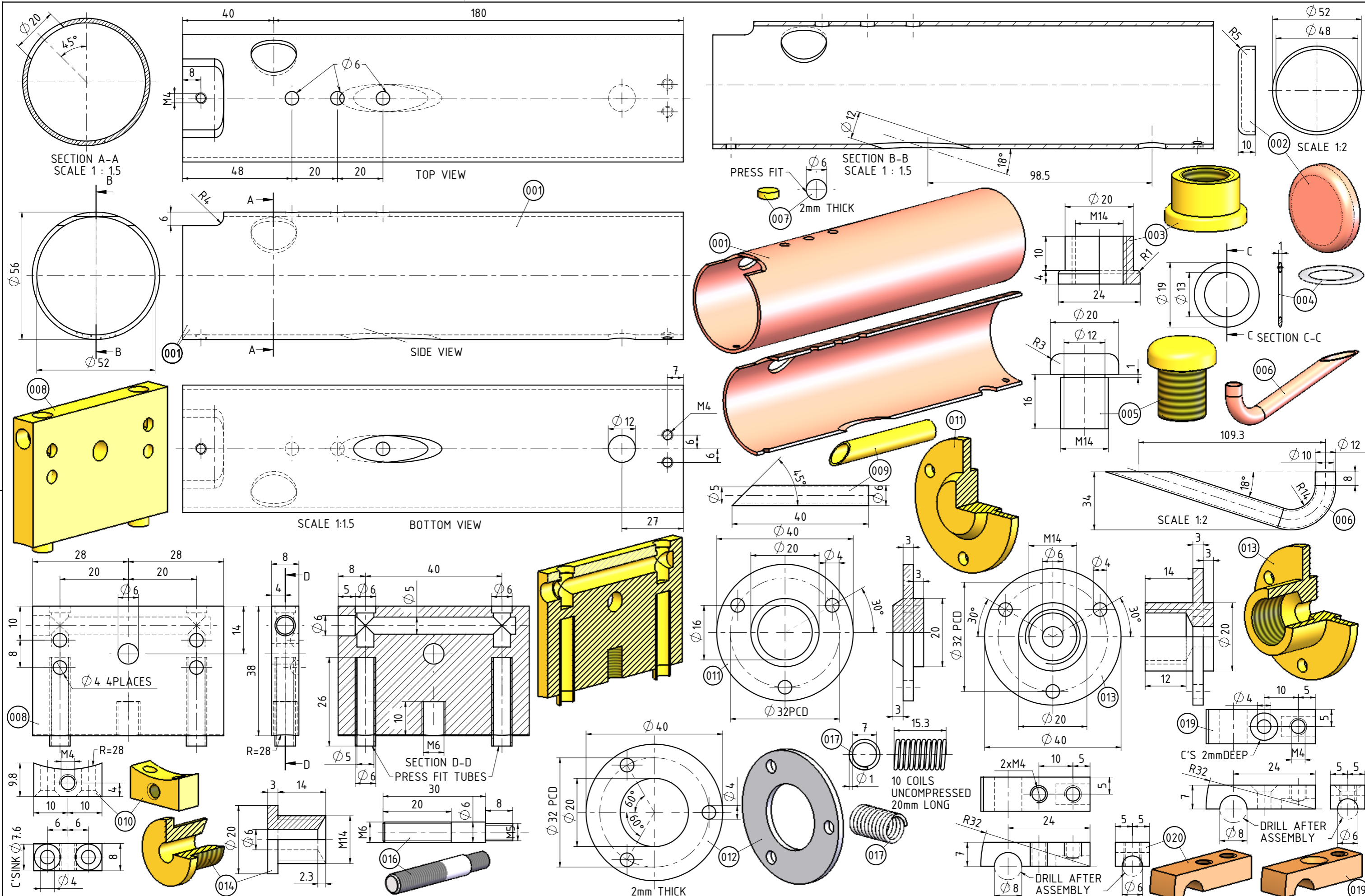

DESIGNED AND BUILT BY Mr W.A. VAN SCHAİK - RESOURCES "DE MODELBOUWER" 8, 9, 10/2000 & 1/2001 -

TITLE
STEAM ROLLER WITH OSCILLATING ENGINE
A3 PARTS

JDW DRAUGHTING SERVICES
 12 BRIGHTWELL STREET
 PAKAPURA NEW ZEALAND
 TEL/FAX 0064-09-2988815
 E-MAIL:dewaal@xtra.co.nz

DRAWN BY J.A.M. DE WAAL	PROJECTION 	DRAWING NUMBER SR-003
DATE APRIL 2010	SCALE 1:1@A3 or AS SHOWN	SHEET 03 of 09
REV DESCRIPTION	DATE	REV A

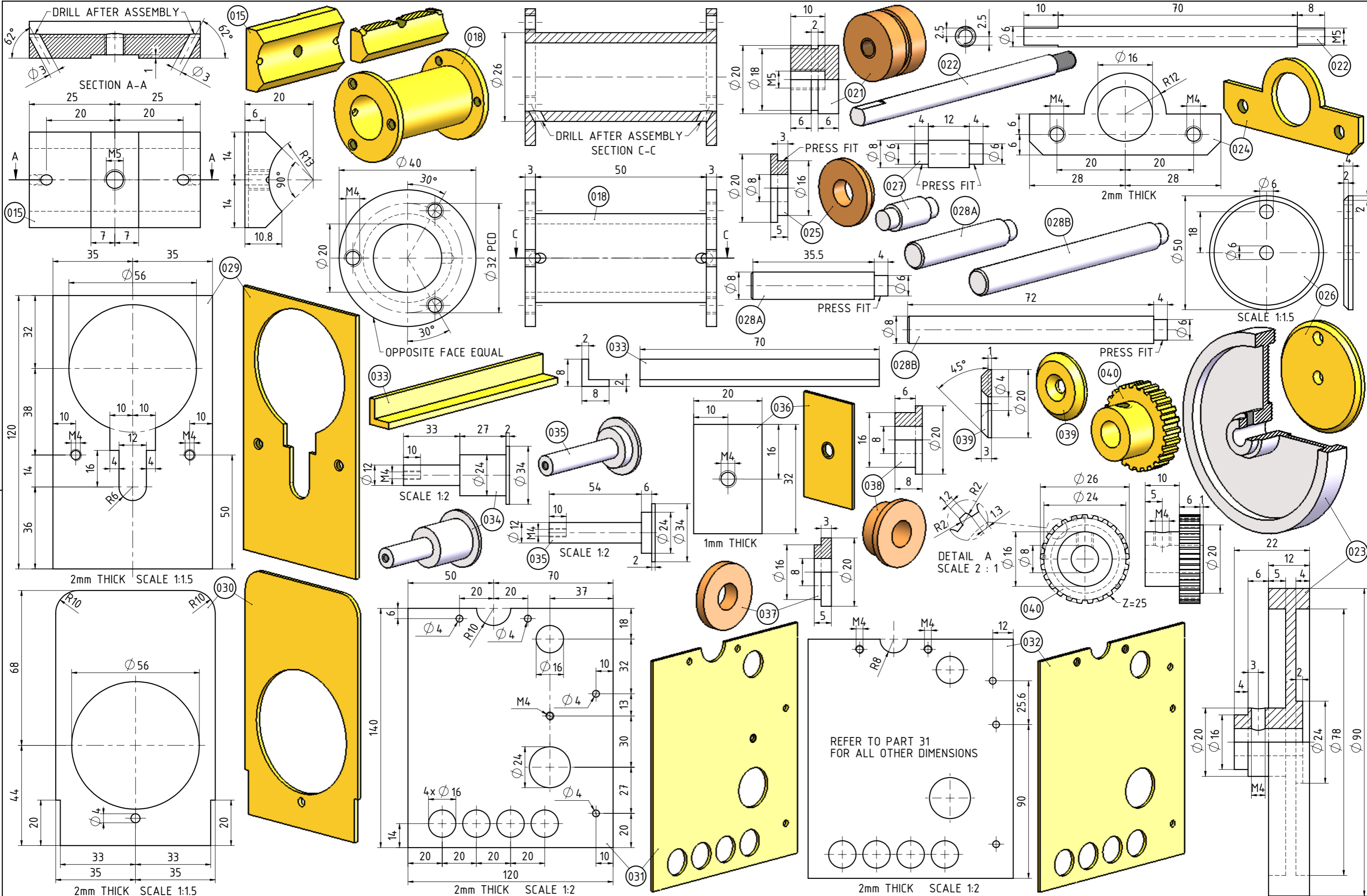

DESIGNED AND BUILT BY Mr W.A. VAN SCHAIK - RESOURCES "DE MODELBOUWER" 8, 9, 10/2000 & 1/2001 -

TITLE	STEAM ROLLER WITH OSCILLATING ENGINE	
A3	PARTS	

JDW DRAUGHTING SERVICES 12 BRIGHTWELL STREET PAKAPURA NEW ZEALAND TEL/FAX 0064-09-2988815 E-MAIL:dewaal@xtra.co.nz		DRAWN BY J.A.M. DE WAAL	PROJECTION FIRST ANGLE	DRAWING NUMBER SR-004
ISSUED FOR CONSTRUCTION	DATE APRIL 2010	SCALE 1:1@A3 or AS SHOWN	SHEET 04 of 09	REV A

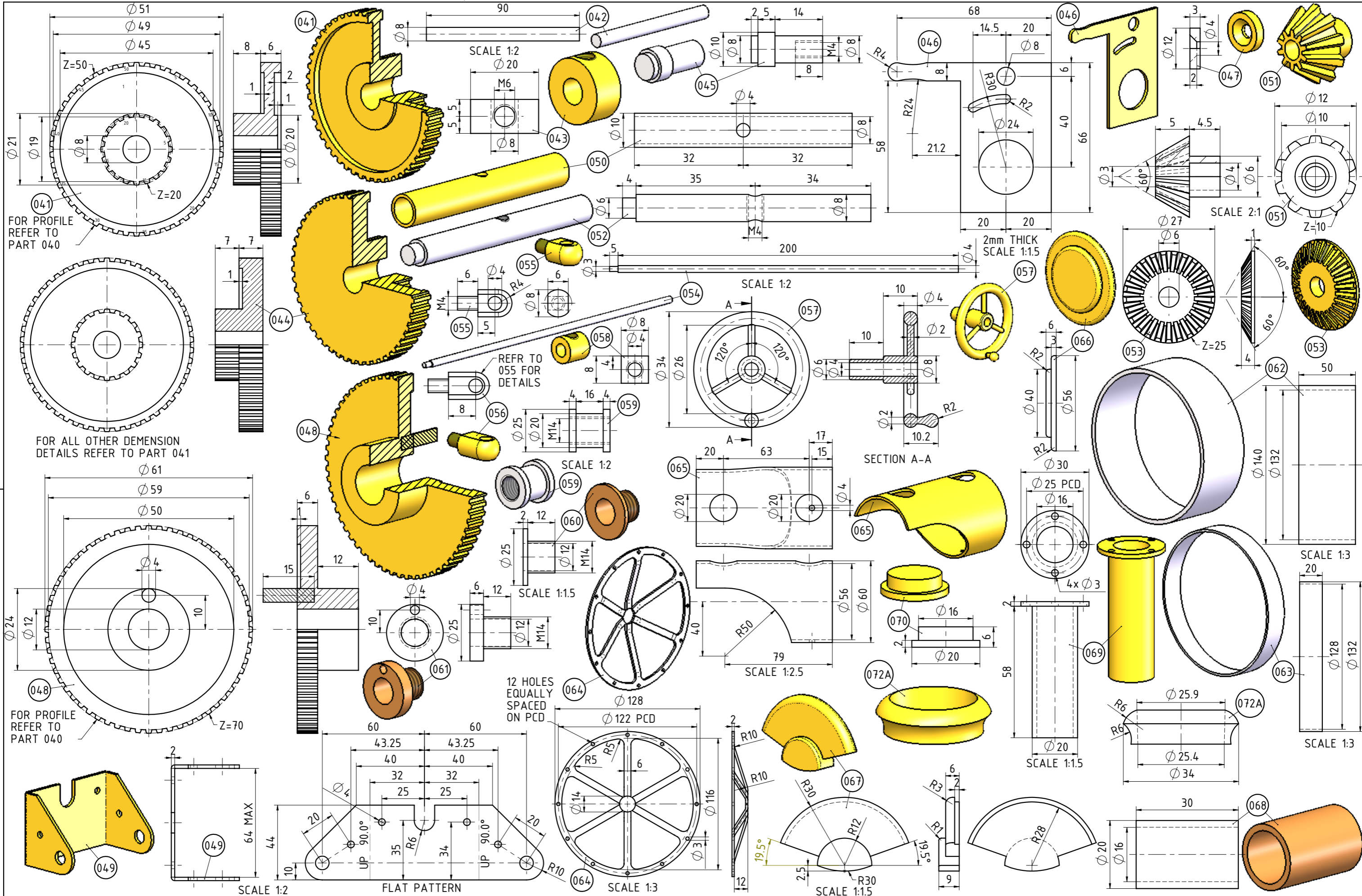

DESIGNED AND BUILT BY Mr W.A. VAN SCHAİK - RESOURCES "DE MODELBOUWER" 8, 9, 10/2000 & 1/2001 -

TITLE
STEAM ROLLER WITH OSCILLATING ENGINE
A3 PARTS

ISSUED FOR CONSTRUCTION	DATE	JDW DRAUGHTING SERVICES 12 BRIGHTWELL STREET PAKAPURA NEW ZEALAND TEL/FAX 0064-09-2988815 E-MAIL:dewaal@xtra.co.nz	DRAWN BY J.A.M. DE WAAL	PROJECTION 	DRAWING NUMBER SR-005
REV	DESCRIPTION	DATE	DATE APRIL 2010	SCALE 1:1@A3 or AS SHOWN	SHEET 05 of 09

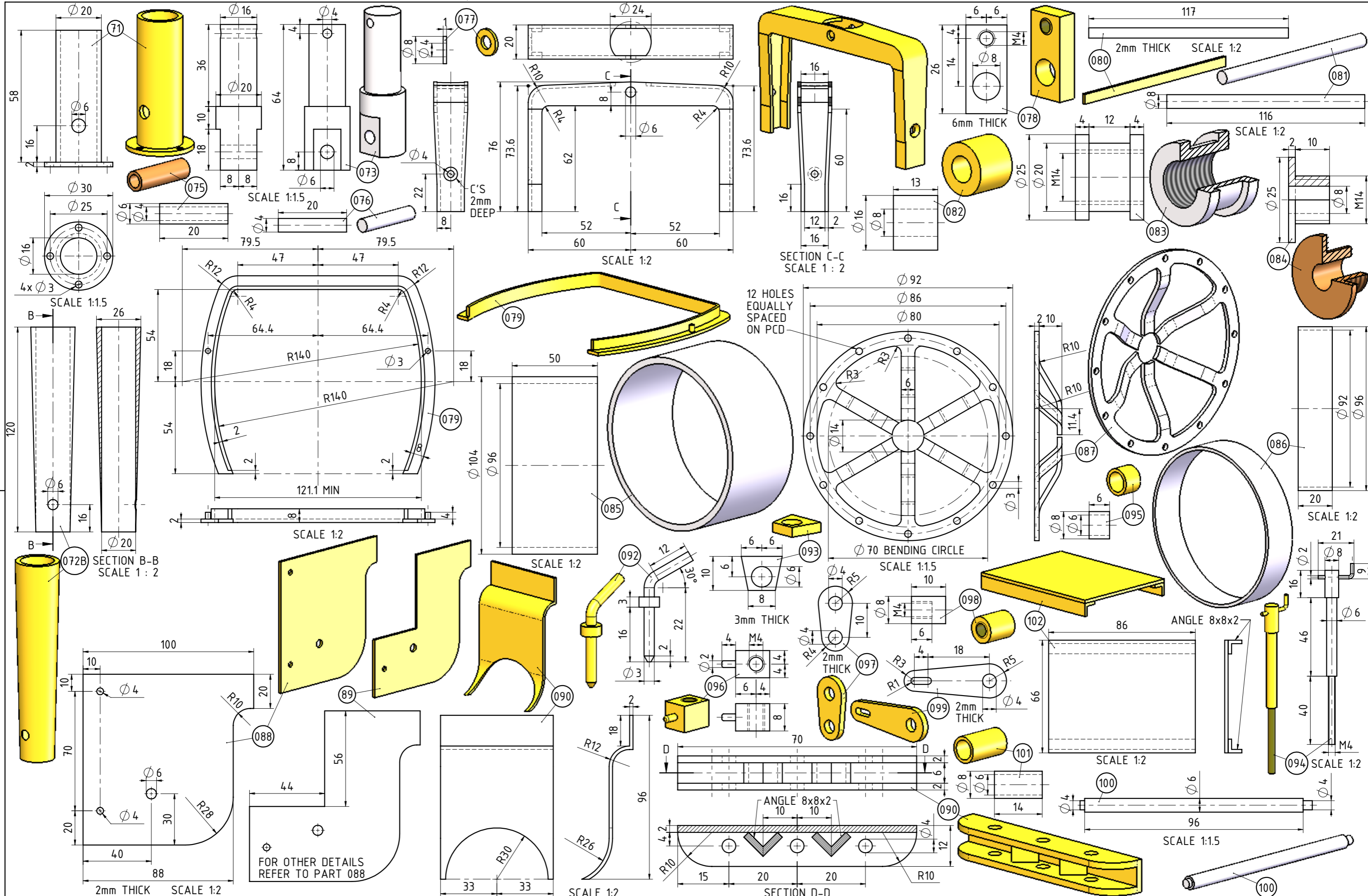

DESIGNED AND BUILT BY Mr W.A. VAN SCHAİK - RESOURCES "DE MODELBOUWER" 8, 9, 10/2000 & 1/2001 -

TITLE
STEAM ROLLER WITH OSCILLATING ENGINE
A3 PARTS

JDW DRAUGHTING SERVICES 12 BRIGHTWELL STREET PAKAPURA NEW ZEALAND TEL/FAX 0064-09-2988815 E-MAIL:dewaal@xtra.co.nz		DRAWN BY J.A.M. DE WAAL	PROJECTION 	DRAWING NUMBER SR-006
A ISSUED FOR CONSTRUCTION REV DESCRIPTION DATE	DATE APRIL 2010	SCALE 1:1@A3 or AS SHOWN	SHEET 06 of 09	REV A

IF NOT STATED ALL CHAMFERS AND FILLETS 0.25mm

DO NOT SCALE OF DRAWING

REMOVE ALL BURS AND SHARP EDGES

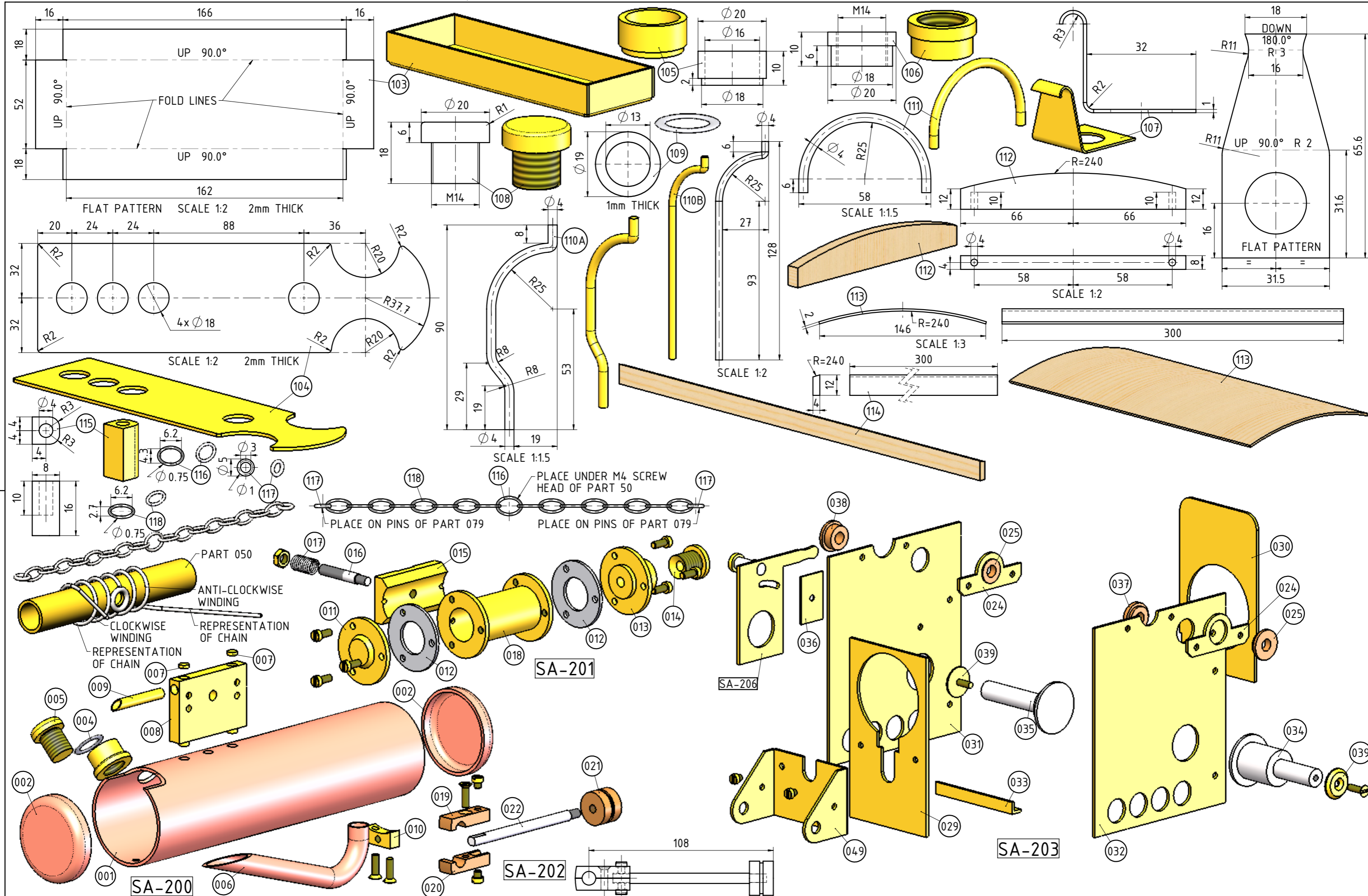

DESIGNED AND BUILT BY Mr W.A. VAN SCHAİK - RESOURCES "DE MODELBOUWER" 8, 9, 10/2000 & 1/2001 -

SA-xxx = SUB ASSEMBLY-xxx

TITLE
STEAM ROLLER WITH OSCILLATING ENGINE
A3 PARTS AND ASSEMBLIES

JDW DRAUGHTING SERVICES
 12 BRIGHTWELL STREET
 PAKAPURA NEW ZEALAND
 TEL/FAX 0064-09-2988815
 E-MAIL:dewaal@xtra.co.nz

DRAWN BY J.A.M. DE WAAL	PROJECTION 	DRAWING NUMBER SR-007
DATE APRIL 2010	SCALE 1:1@A3 or AS SHOWN	SHEET 07 of 09

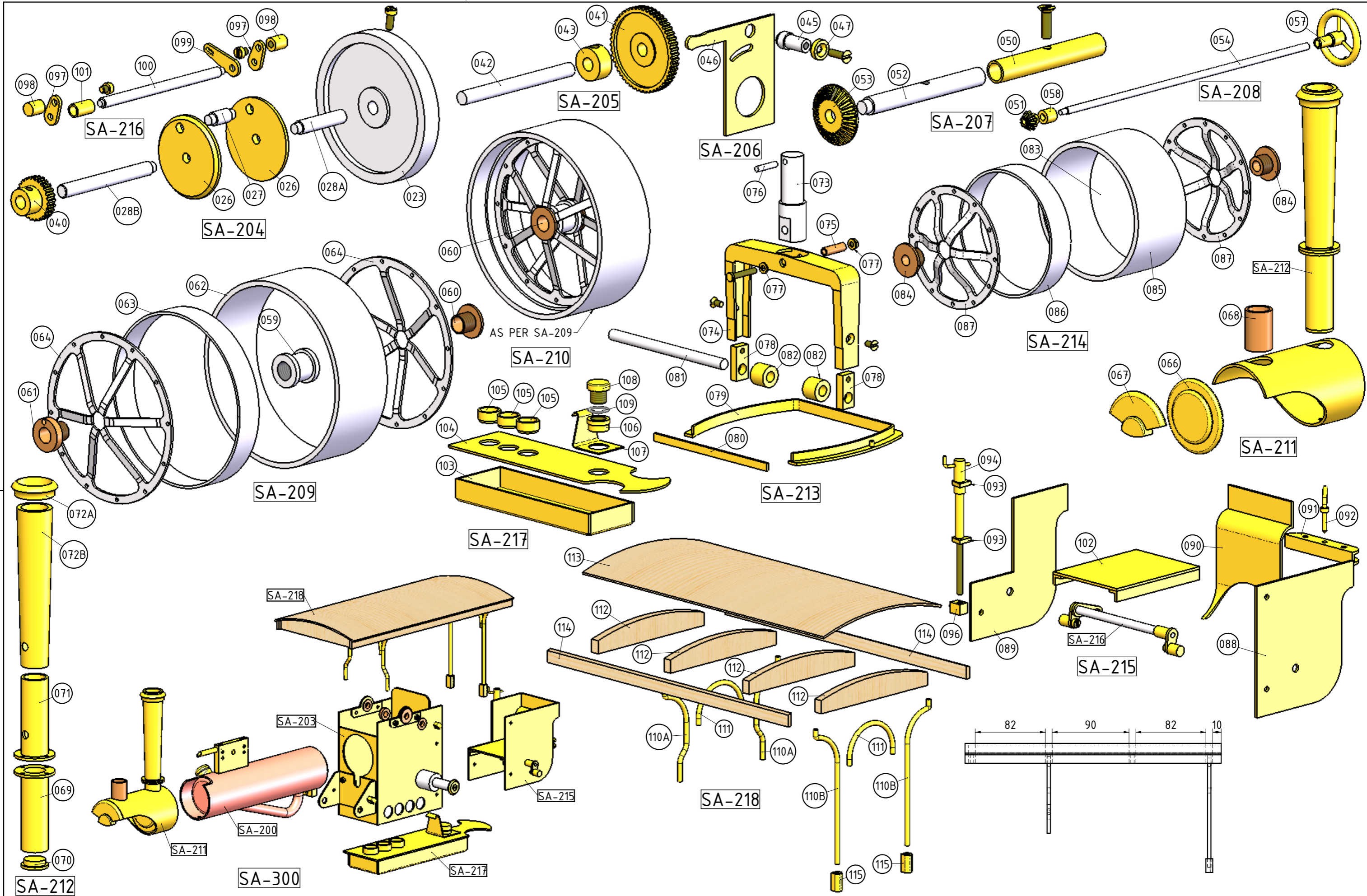

DESIGNED AND BUILT BY Mr W.A. VAN SCHAİK - RESOURCES "DE MODELBOUWER" 8, 9, 10/2000 & 1/2001 -

SA-xxx = SUB ASSEMBLY-xxx

TITLE
STEAM ROLLER WITH OSCILLATING ENGINE
A3 PARTS AND ASSEMBLIES

JDW DRAUGHTING SERVICES
 12 BRIGHTWELL STREET
 PAKAPURA NEW ZEALAND
 TEL/FAX 0064-09-2988815
 E-MAIL:dewaal@xtra.co.nz

DRAWN BY
 J.A.M. DE WAAL
 DATE
 APRIL 2010

PROJECTION

 SCALE
 1:1@A3 or AS SHOWN

DRAWING NUMBER
 SR-008
 SHEET
 08 of 09
 REV
 A

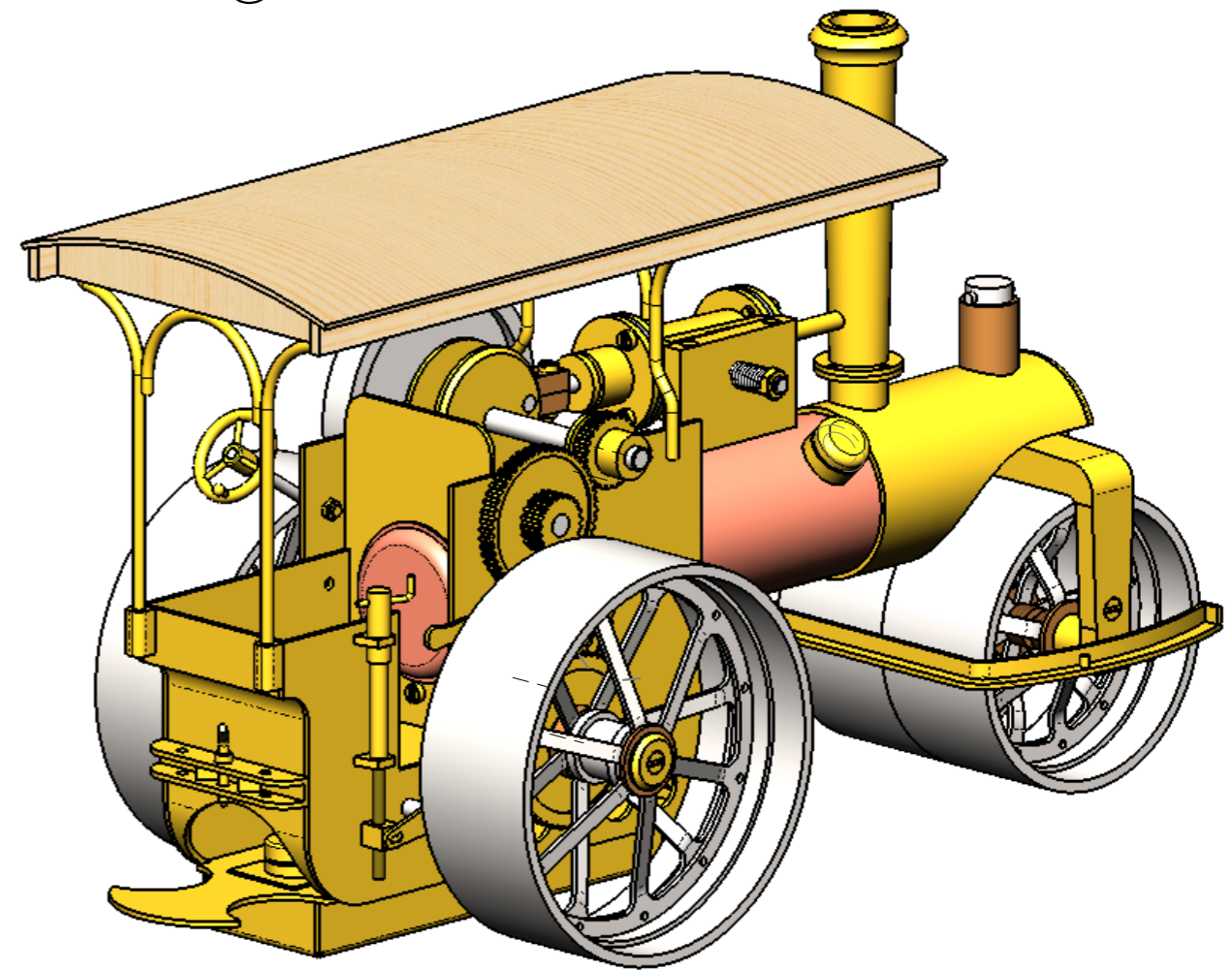
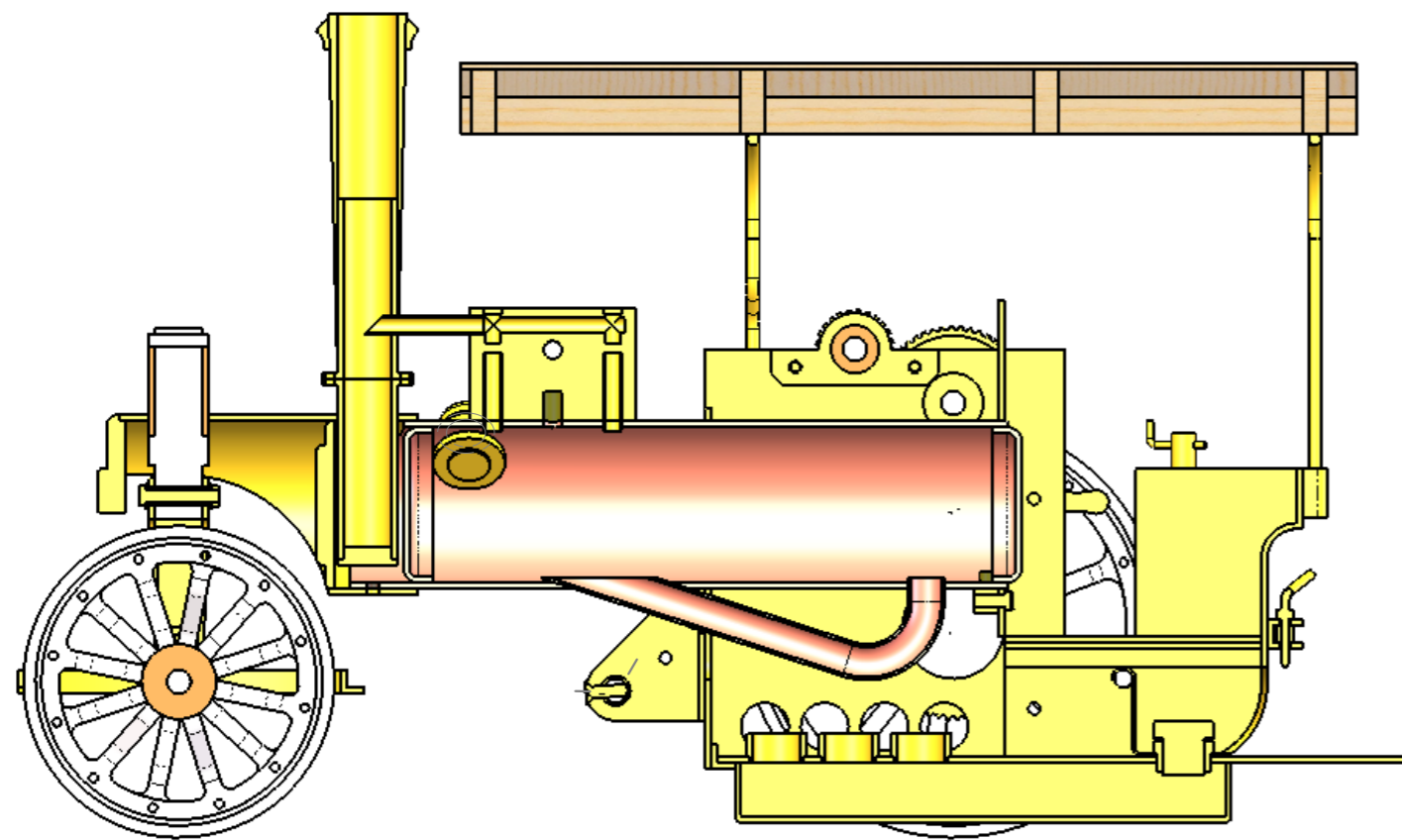
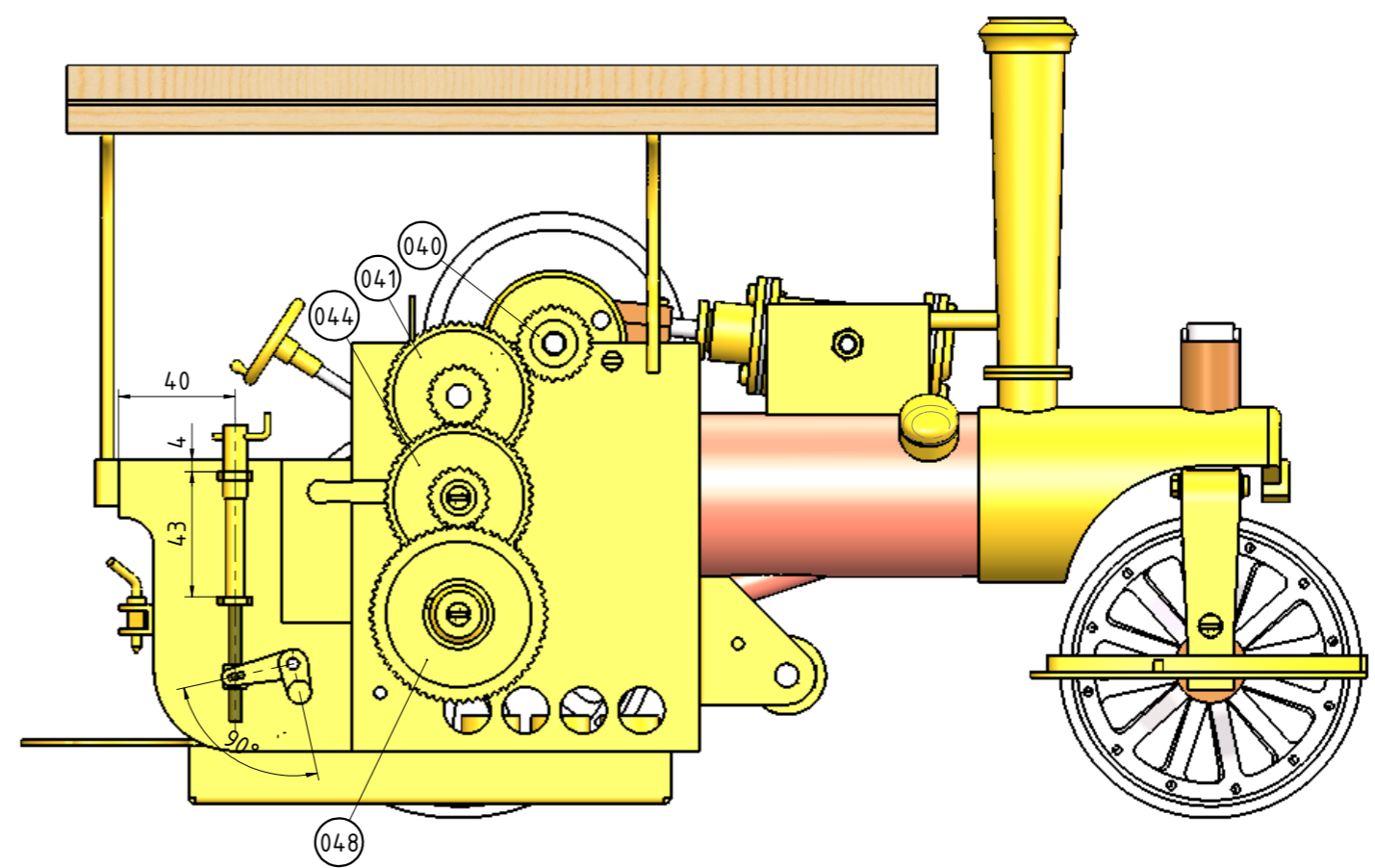
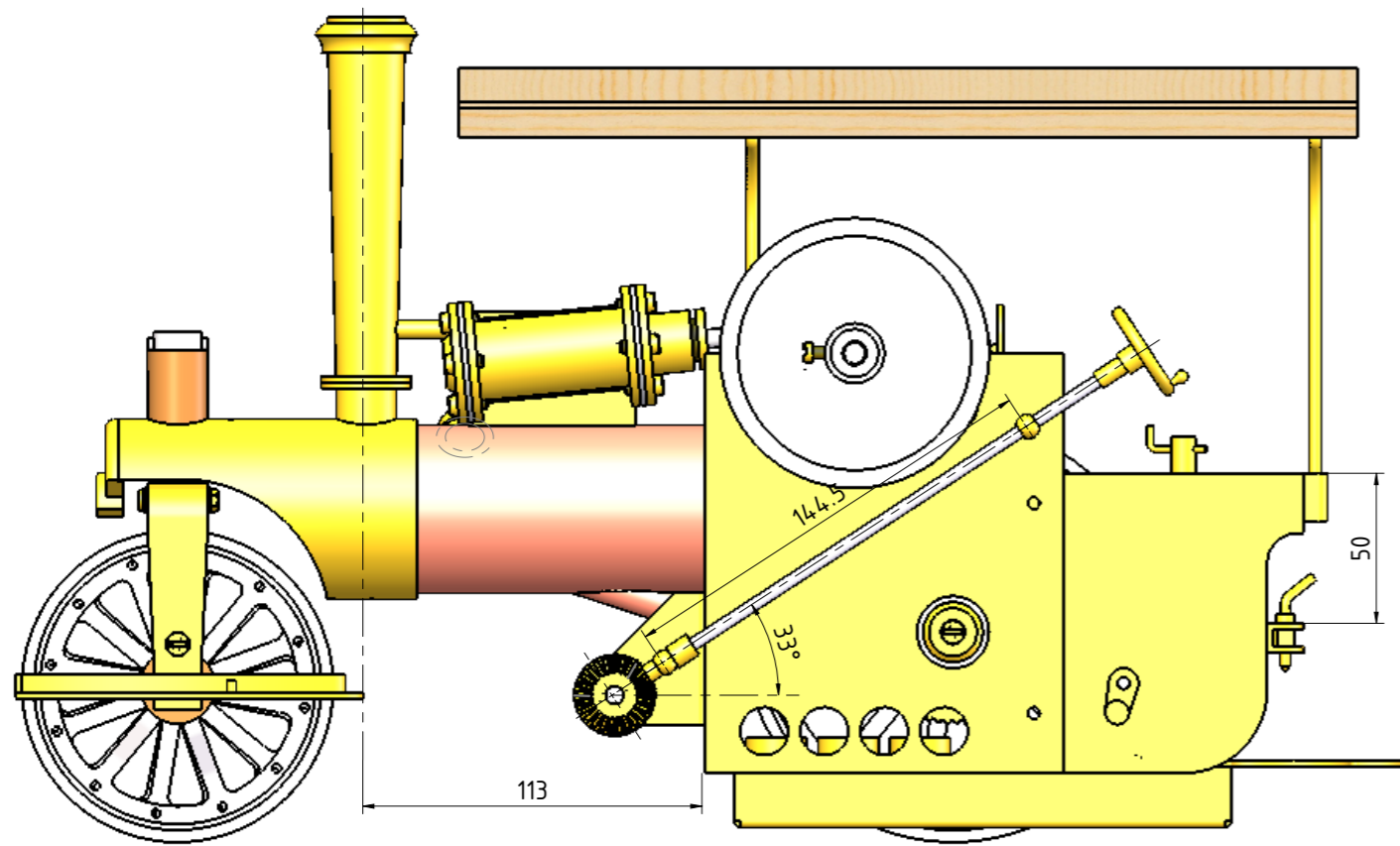

DESIGNED AND BUILT BY Mr W.A. VAN SCHAİK - RESOURCES "DE MODELBOUWER" 8, 9, 10/2000 & 1/2001 -

SA-xxx = SUB ASSEMBLY-xxx

TITLE
STEAM ROLLER WITH OSCILLATING ENGINE
A3 PARTS AND ASSEMBLIES

REV	DESCRIPTION	DATE	JDW DRAUGHTING SERVICES 12 BRIGHTWELL STREET PAKAPURA NEW ZEALAND TEL/FAX 0064-09-2988815 E-MAIL:dewaal@xtra.co.nz
A	ISSUED FOR CONSTRUCTION		

DRAWN BY
J.A.M. DE WAAL
 DATE
APRIL 2010

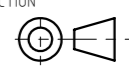
PROJECTION

 SCALE
1:1@A3 or AS SHOWN

DRAWING NUMBER
SR-009
 SHEET
09 of 09
 REV
A

IF NOT STATED ALL CHAMFERS AND FILLETS 0.25mm

DO NOT SCALE OF DRAWING

REMOVE ALL BURS AND SHARP EDGES