

STOOM LOKOMOTIEF MET OSCILLERENDE STOOMMACINE "CRACKER" DESIGNED BY: ERNEST GLASER ONWORPEN DOOR: ERNEST GLASER CONVERTED FROM O-SCALE (32mm) TO G-SCALE (45mm) BY J.A.M. DE WAAL

A3 TITLE  
**STEAM LOCOMOTIVE WITH OSCILATING STEAM ENGINE "CRACKER"**  
**GENERAL ARRANGEMENT**

REV	DESCRIPTION	DATE
A	ISSUED FOR CONSTRUCTION	

JDW DRAUGHTING SERVICES  
 12 BRIGHTWELL STREET  
 PAKAKURA NEW ZEALAND  
 TEL/FAX 0064-09-2988815  
 E-MAIL:dewaal@xtra.co.nz

DRAWN BY  
**J.A.M. DE WAAL**  
 DATE  
 JULY 2009

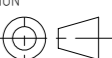
PROJECTION  
  
 SCALE 1:1 or AS SHOWN

DRAWING NUMBER  
**CRACKER 00**  
 SHEET  
**00**  
 CAD FILE  
 REV  
**A**

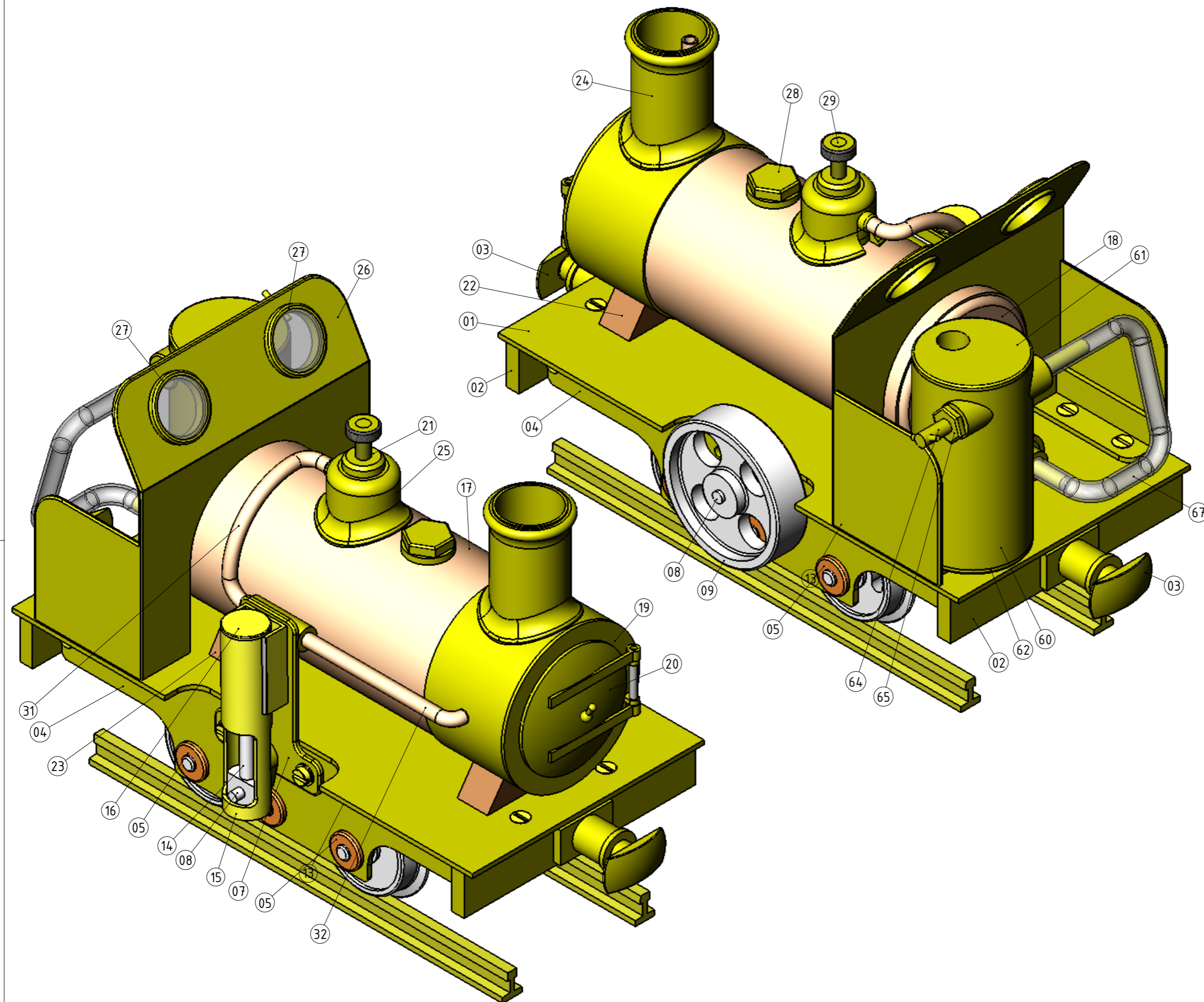

QTY.	PART NUMBER
1	CRACKER-01-RUNNING PLATE
2	CRACKER-02-BUFFERBEAM
2	CRACKER-03-BUFFER
2	CRACKER-04-SIDE FRAME
6	CRACKER-05-WHEEL BEARING
1	CRACKER-06-CRANK SHAFT BEARING
1	CRACKER-07-PORT BLOCK
1	CRACKER-08-CRANKSHAFT
1	CRACKER-09-FLYWHEEL
1	CRACKER-10-SMALL GEAR WHEEL
1	CRACKER-11-LARGE GEAR WHEEL IDLER
2	CRACKER-12-LARGE GEAR WHEEL
2	CRACKER-13-WHEELS AND AXLE
1	CRACKER-14-PISTON
1	CRACKER-15-CYLINDER
1	CRACKER-16-CYLINDER LID
1	CRACKER-17-BOILER
1	CRACKER-18-BOILER ENDS
1	CRACKER-19-SMOKE BOX DOOR SURROUND
1	CRACKER-20-SMOKE BOX DOOR
1	CRACKER-21-STEAM DOME
1	CRACKER-22-SMOKE BOX SADDLE
1	CRACKER-23-BOILER SADDLE
1	CRACKER-24-CHIMNEY SURROUND
1	CRACKER-25-STEAM DOME COVER
1	CRACKER-26-CAB
2	CRACKER-27-CAB WINDOWS
1	CRACKER-28-FILLER LID
1	CRACKER-29-STEAM DOME VALVE
1	CRACKER-30-STEAM VALVE O-RING
1	CRACKER-31-STEAM SUPPLY LINE
1	CRACKER-32-STEAM EXHAUST LINE
1	CRACKER-33-SPRING
1	CRACKER-40-BURNER TUBE
1	CRACKER-41-BURNER TUBE CAP
1	CRACKER-42-BURNER TUBE RING
1	CRACKER-43-JET-ORIFICE
1	CRACKER-44-BURNER TUBE COVER
1	CRACKER-60-GASTANK BODY
1	CRACKER-61-GASTANK TOP LID
1	CRACKER-62-GASTANK BOTTOM LID
1	CRACKER-63-GASTANK CONTROL VALVE BODY
1	CRACKER-64-GASTANK CONTROL VALVE
1	CRACKER-65-GASTANK RETAINER NUT
1	CRACKER-66-GASTANK O-RING
1	CRACKER-67-GASTANK SUPPLY HOSE
1	CRACKER-M2x5.2 COUNTERSINK SCREW
8	CRACKER-M3 NUT
9	CRACKER-M3 WASHER
1	CRACKER-M3x10 CHEESEHEAD SCREW
4	CRACKER-M3x5 COUNTERSINK SCREW
6	CRACKER-M3x8 CHEESEHEAD SCREW
4	CRACKER-M3x8 COUNTERSINK SCREW
2	CRACKER-M5x20 COUNTERSINK SCREW
1	LGB RAIL CODE 338

STOOM LOKOMOTIEF MET OSCILLERENDE STOOMMACINE "CRACKER" DESIGNED BY: ERNEST GLASER ONWORPEN DOOR: ERNEST GLASER CONVERTED FROM O-SCALE (32mm) TO G-SCALE (45mm) BY J.A.M. DE WAAL

TITLE  
**STEAM LOCOMOTIVE WITH OSCILATING STEAM ENGINE "CRACKER"**  
**ISOMETRIC VIEWS AND BILL OF MATERIALS**

A3

JDW DRAUGHTING SERVICES  
 12 BRIGHTWELL STREET  
 PAKAPURA NEW ZEALAND  
 TEL/FAX 0064-09-2988815  
 E-MAIL:dewaal@xtra.co.nz

ISSUED FOR CONSTRUCTION	DATE
DESCRIPTION	DATE

DRAWN BY J.A.M. DE WAAL	PROJECTION 	DRAWING NUMBER CRACKER 01	SHEET 01
DATE JULY 2009	SCALE 1:1 or AS SHOWN	CAD FILE	REV A

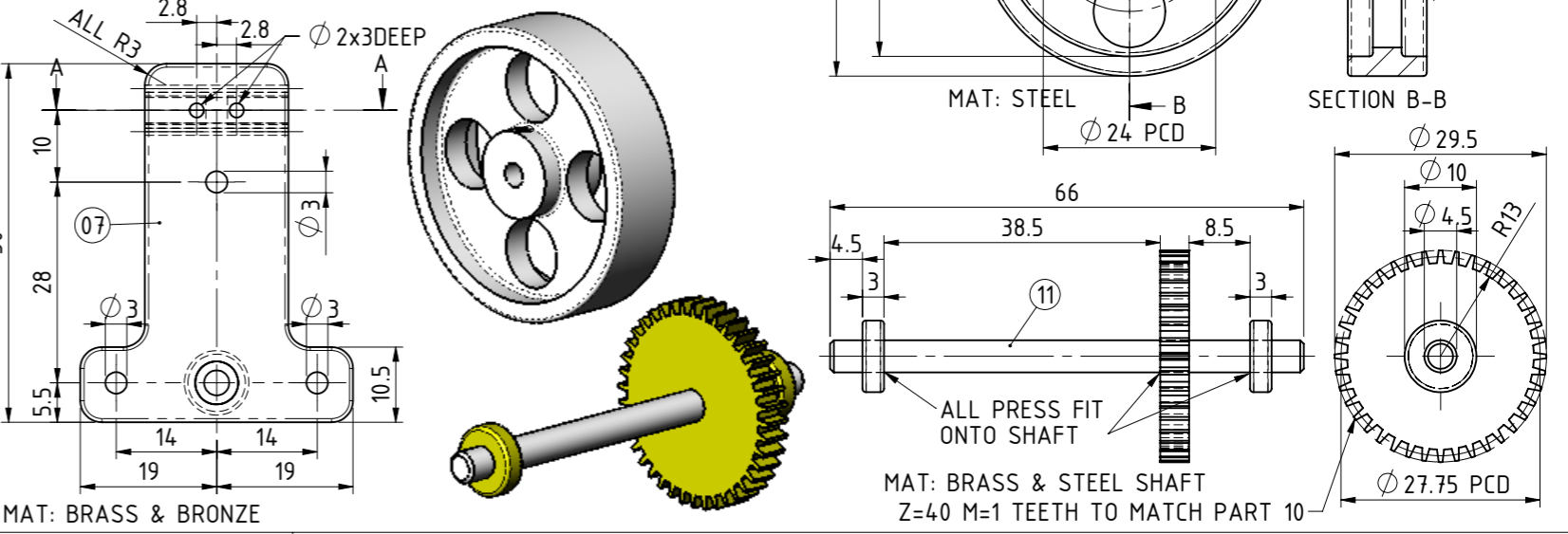
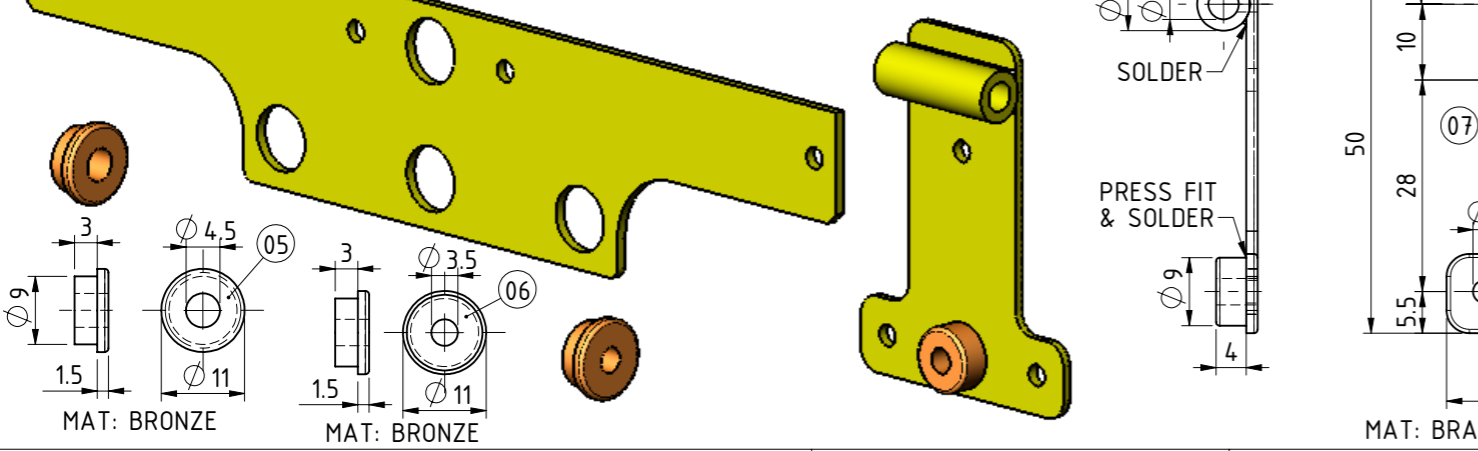
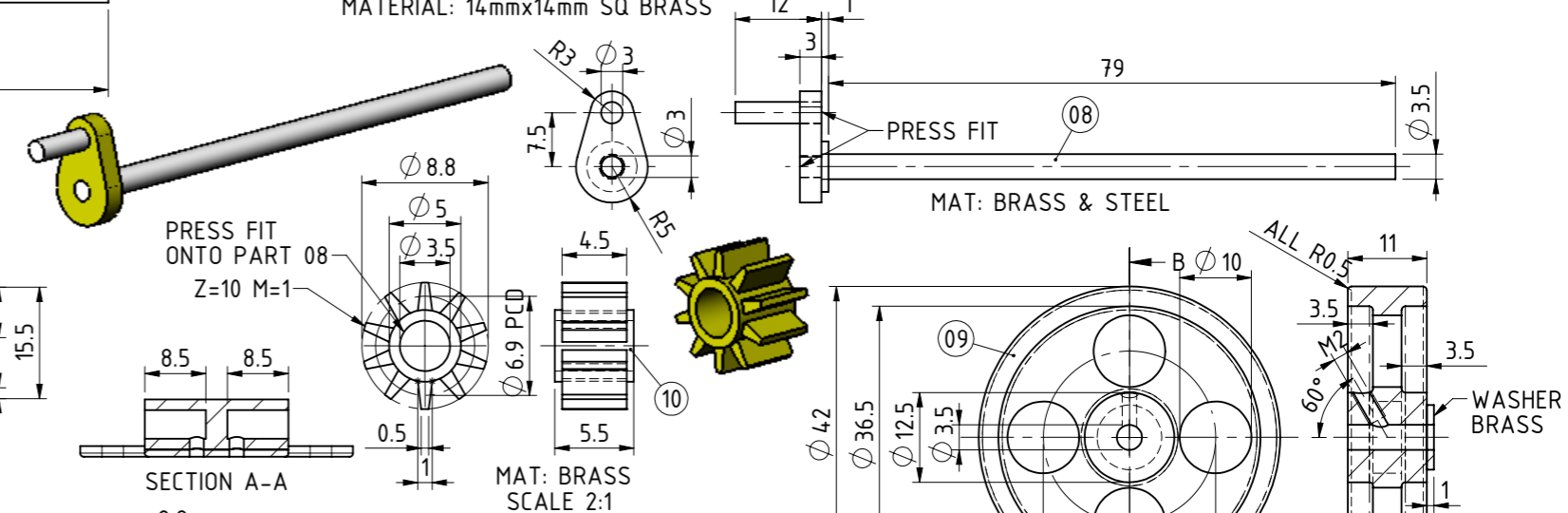
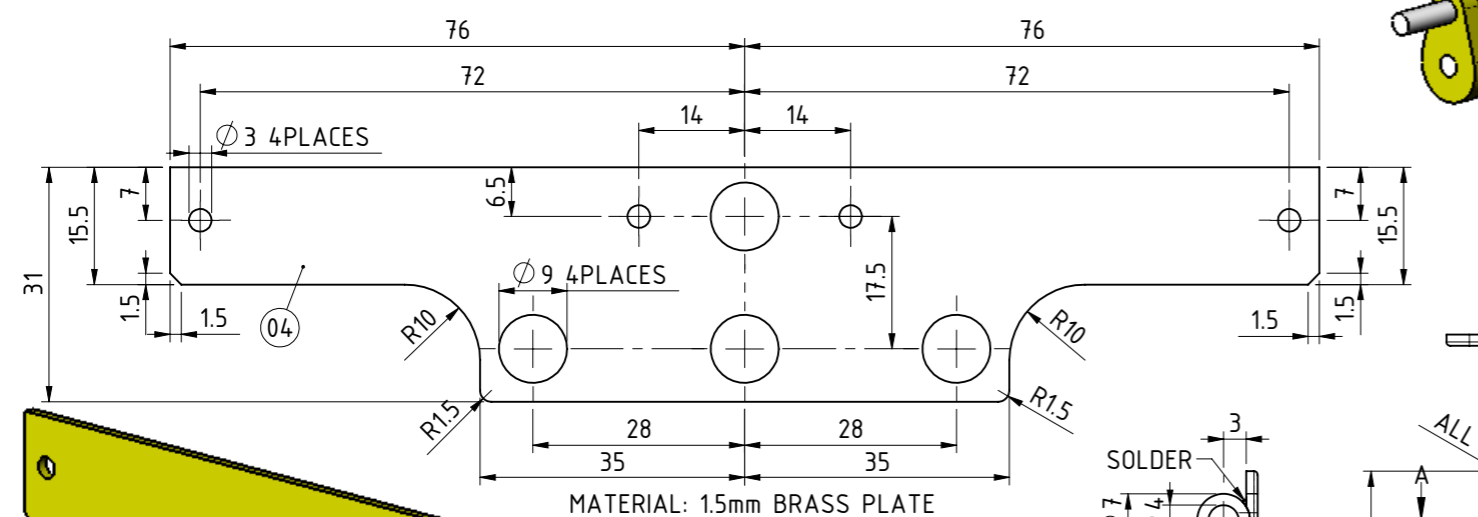
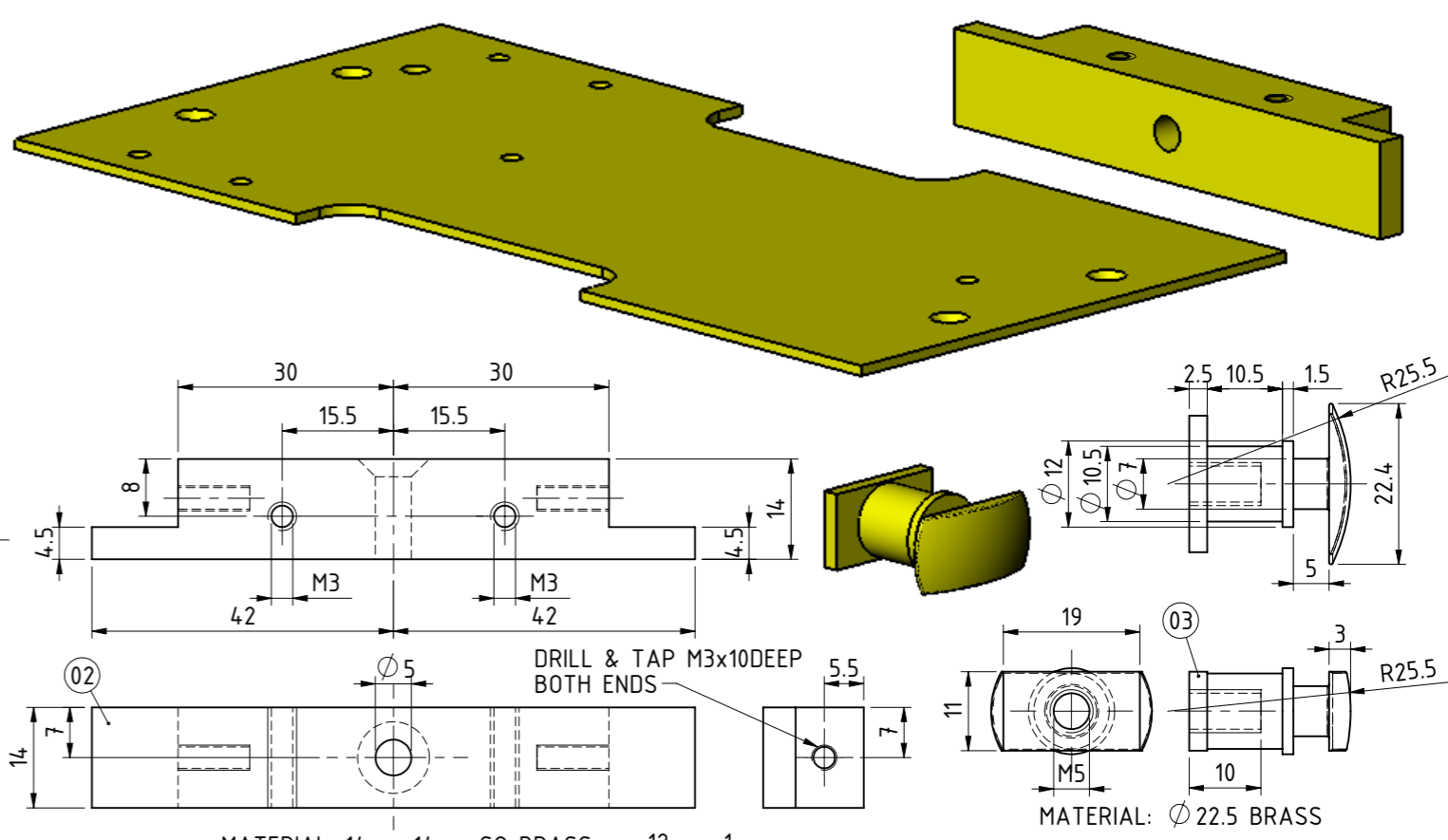
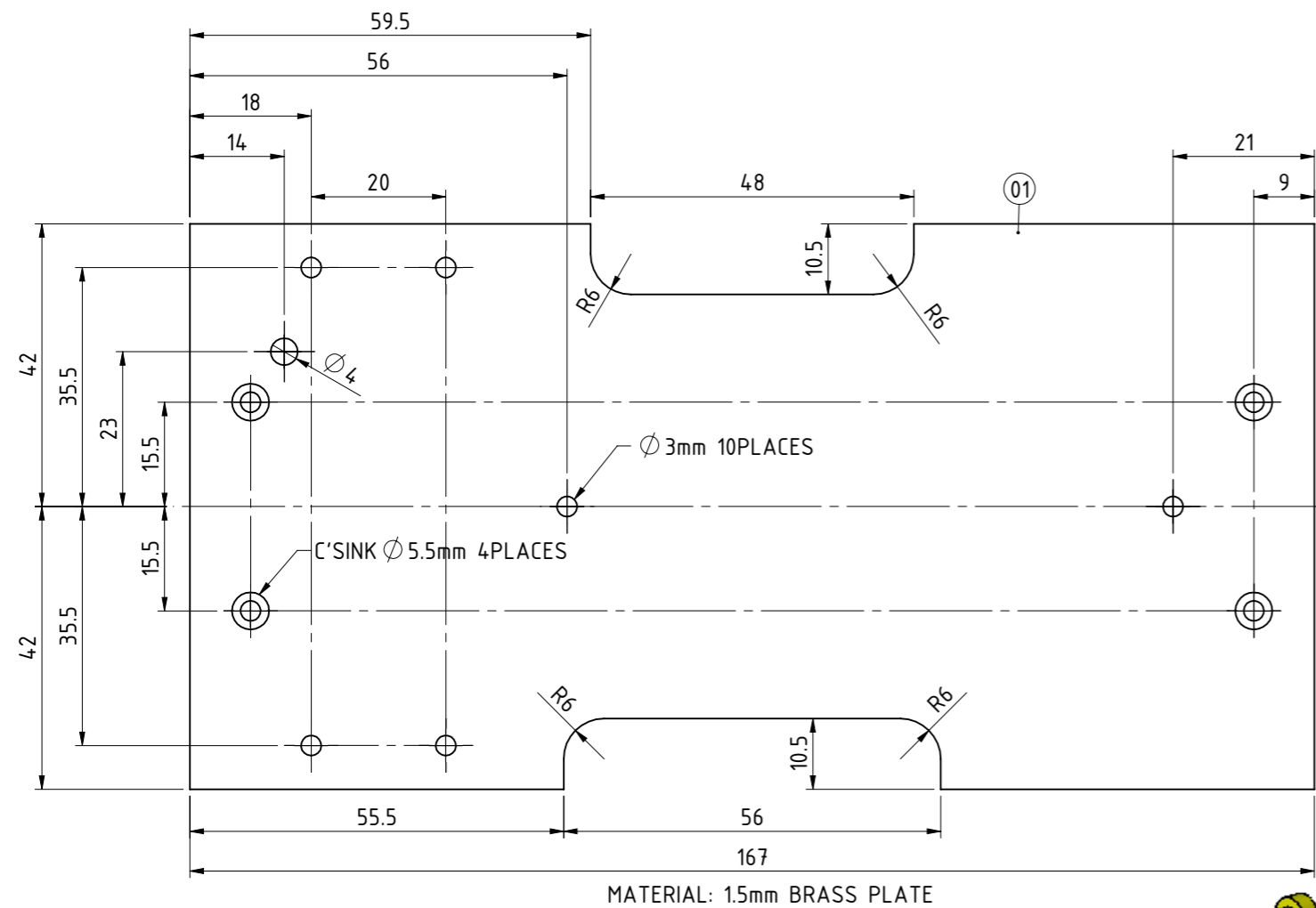

STOOM LOKOMOTIEF MET OSCILLERENDE STOOMMACINE "CRACKER" DESIGNED BY: ERNEST GLASER ONWORPEN DOOR: ERNEST GLASER CONVERTED FROM O-SCALE (32mm) TO G-SCALE (45mm) BY J.A.M. DE WAAL

A3	TITLE		DRAWN BY		PROJECTION	DRAWING NUMBER		SHEET
	STEAM LOCOMOTIVE WITH OSCILATING STEAM ENGINE "CRACKER" COMPONENTS/PARTS		J.A.M. DE WAAL			CRACKER 02		
REV		DESCRIPTION		DATE		SCALE		REV
				JULY 2009		1:1 or AS SHOWN		

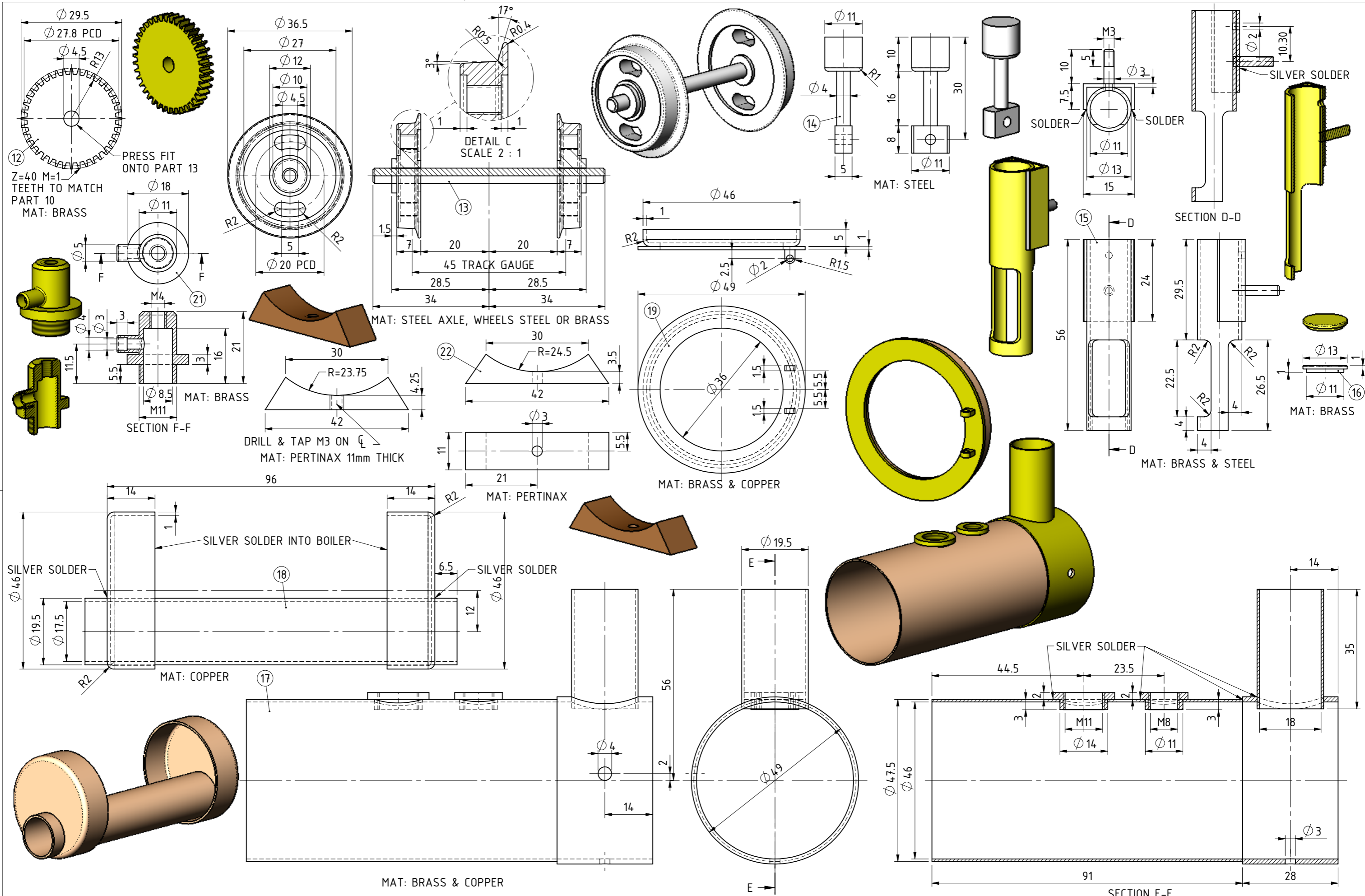

STOOM LOKOMOTIEF MET OSCILLERENDE STOOMMACINE "CRACKER" DESIGNED BY: ERNEST GLASER ONWORPEN DOOR: ERNEST GLASER CONVERTED FROM O-SCALE (32mm) TO G-SCALE (45mm) BY J.A.M. DE WAAL

A3	TITLE		DRAWN BY		PROJECTION		DRAWING NUMBER		SHEET		
	STEAM LOCOMOTIVE WITH OSCILATING STEAM ENGINE "CRACKER" COMPONENTS/PARTS		J.A.M. DE WAAL		AS SHOWN		CRACKER		03		
REV		DESCRIPTION		DATE		SCALE		CAD FILE		REV	
				JULY 2009		1:1 or AS SHOWN				A	

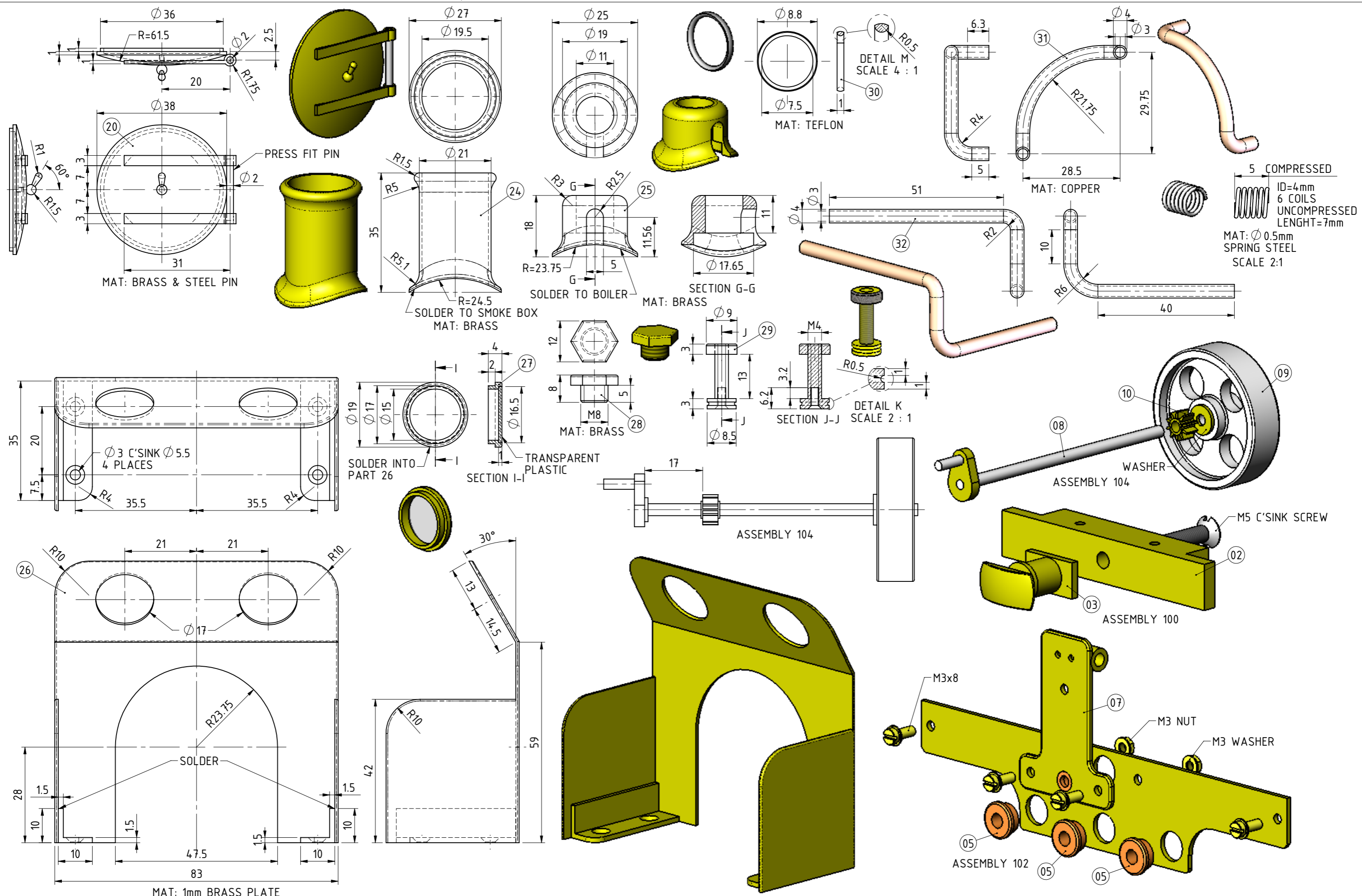

STOOM LOKOMOTIEF MET OSCILLERENDE STOOMMACINE "CRACKER" DESIGNED BY: ERNEST GLASER ONWORPEN DOOR: ERNEST GLASER CONVERTED FROM O-SCALE (32mm) TO G-SCALE (45mm) BY J.A.M. DE WAAL

TITLE	STEAM LOCOMOTIVE WITH OSCILATING STEAM ENGINE "CRACKER"	
A3	COMPONENTS/PARTS & EXPLODED VIEWS	

JDW DRAUGHTING SERVICES 12 BRIGHTWELL STREET PAKAPURA NEW ZEALAND TEL/FAX 0064-09-2988815 E-MAIL:dewaal@xtra.co.nz	DRAWN BY J.A.M. DE WAAL	PROJECTION AS SHOWN	DRAWING NUMBER CRACKER	SHEET 04
A ISSUED FOR CONSTRUCTION	DATE JULY 2009	SCALE 1:1	CAD FILE	REV A

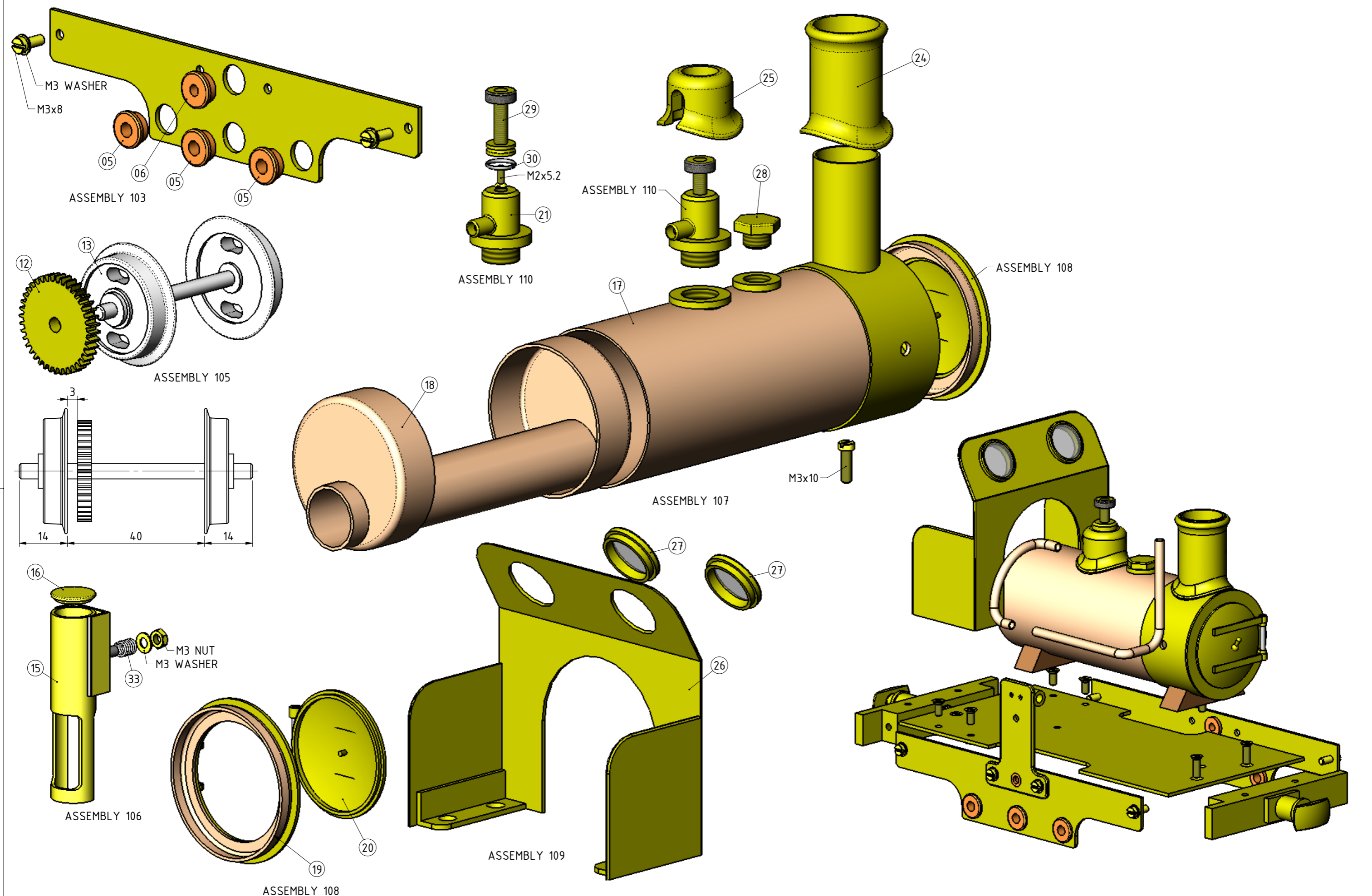

STOOM LOKOMOTIEF MET OSCILLERENDE STOOMMACINE "CRACKER" | DESIGNED BY: ERNEST GLASER | ONWORPEN DOOR: ERNEST GLASER | CONVERTED FROM O-SCALE (32mm) TO G-SCALE (45mm) BY J.A.M. DE WAAL

A3	TITLE	STEAM LOCOMOTIVE WITH OSCILATING STEAM ENGINE "CRACKER"
	EXPLODED VIEWS	

REV	DESCRIPTION	DATE
A	ISSUED FOR CONSTRUCTION	

JDW DRAUGHTING SERVICES  
 12 BRIGHTWELL STREET  
 PAKAKURA NEW ZEALAND  
 TEL/FAX 0064-09-2988815  
 E-MAIL:dewaal@xtra.co.nz

DRAWN BY  
 J.A.M. DE WAAL  
 DATE  
 JULY 2009

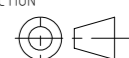
PROJECTION  
  
 SCALE 1:1 or AS SHOWN

DRAWING NUMBER	CRACKER	SHEET	05
CAD FILE		REV	A

QTY.	PART NUMBER
1	CRACKER-60-GASTANK BODY
1	CRACKER-61-GASTANK TOP LID
1	CRACKER-62-GASTANK BOTTOM LID
1	CRACKER-63-GASTANK CONTROL VALVE BODY
1	CRACKER-64-GASTANK CONTROL VALVE
1	CRACKER-65-GASTANK RETAINER NUT
1	CRACKER-66-GASTANK O-RING

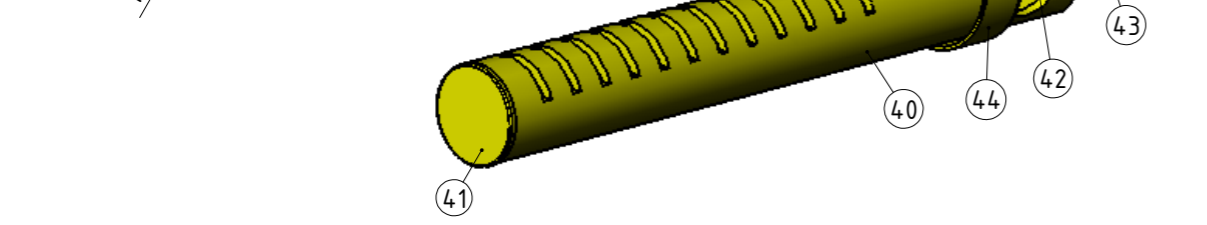
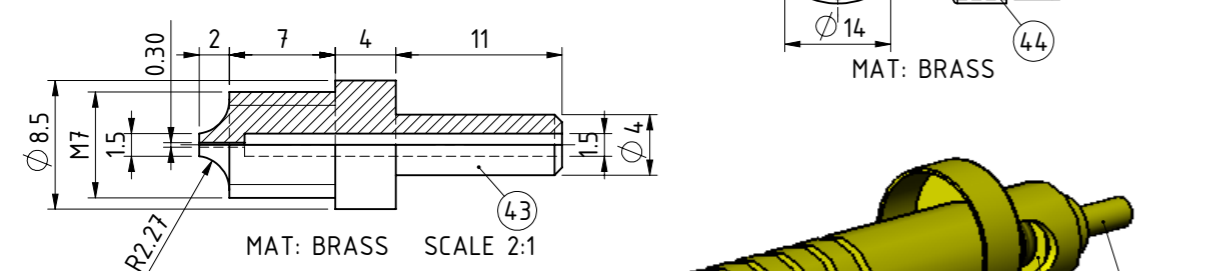
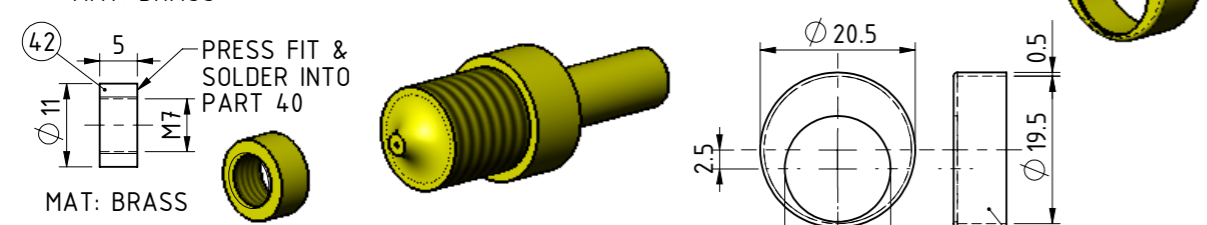
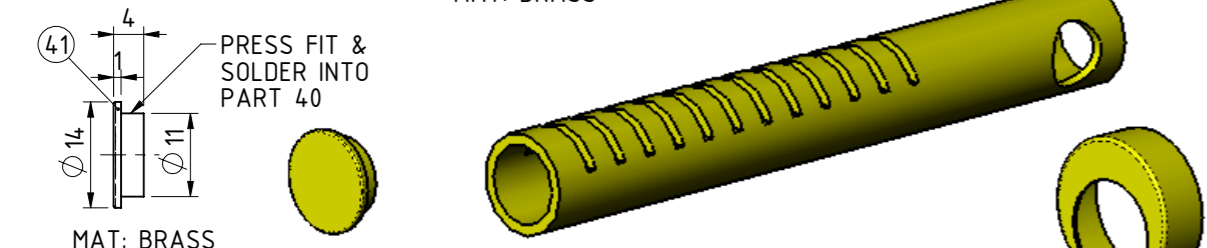
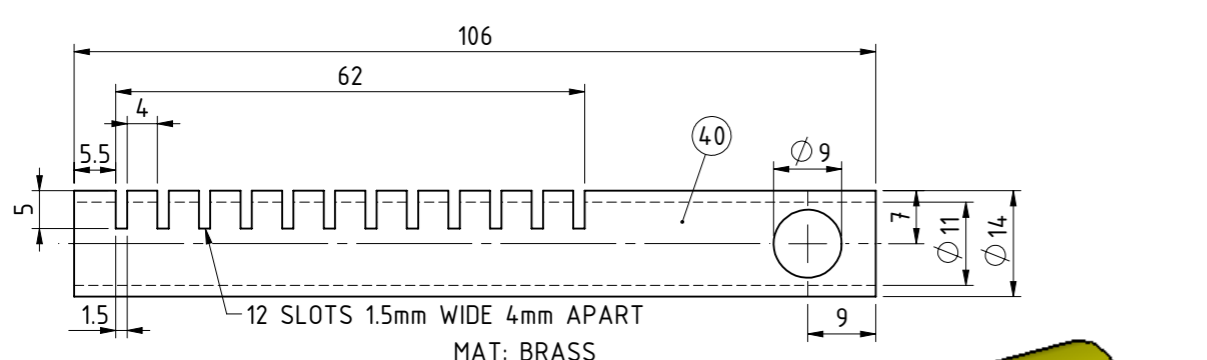
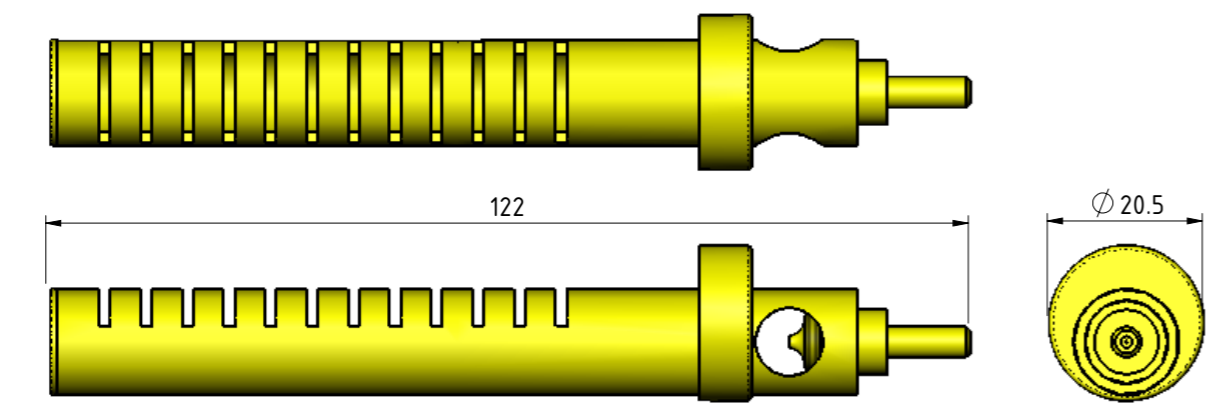

QTY.	PART NUMBER
1	CRACKER-40-BURNER TUBE
1	CRACKER-41-BURNER TUBE CAP
1	CRACKER-42-BURNER TUBE RING
1	CRACKER-43-JET-ORIFICE
1	CRACKER-44-BURNER TUBE COVER

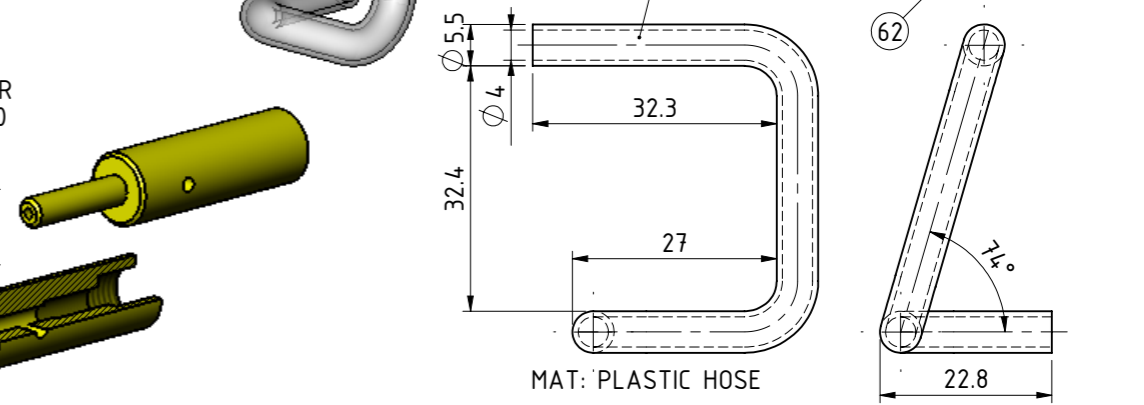
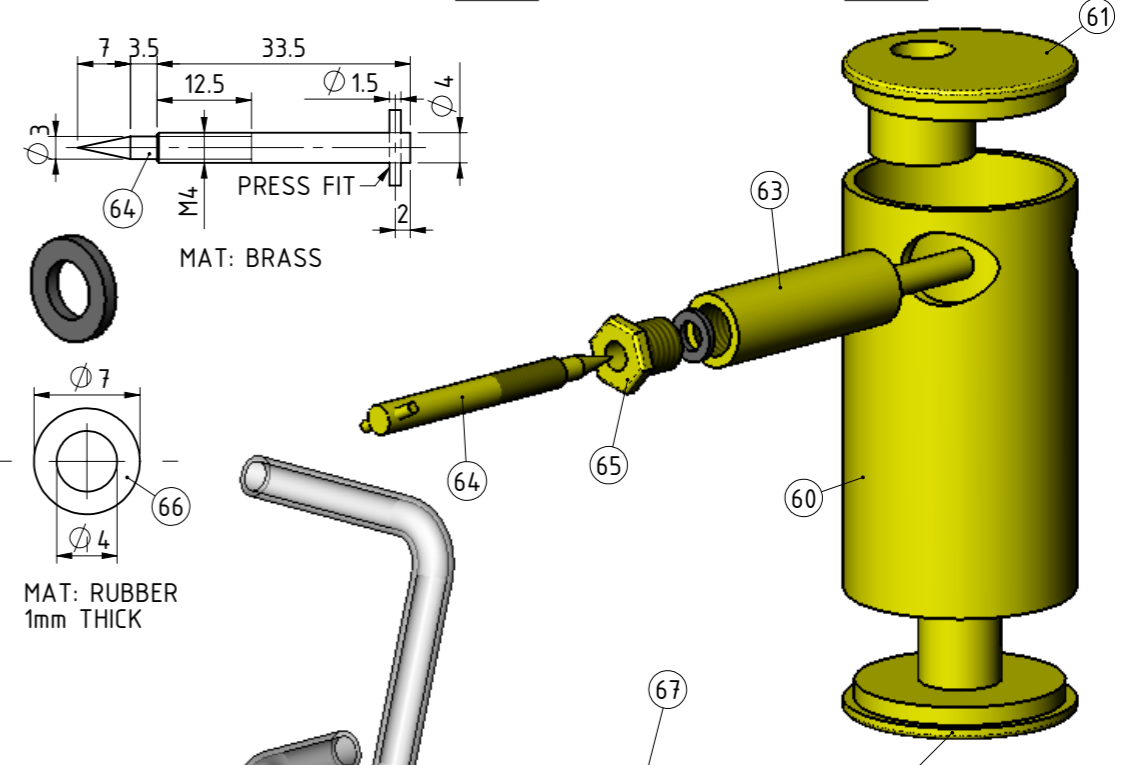
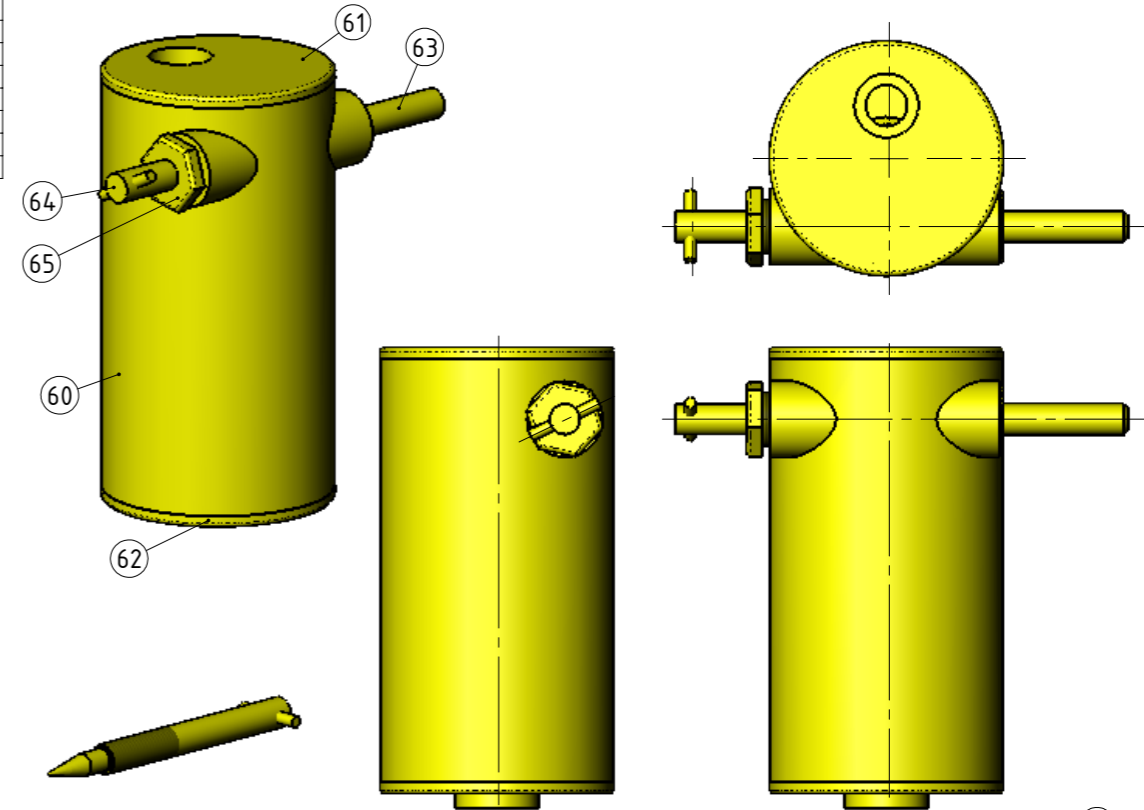
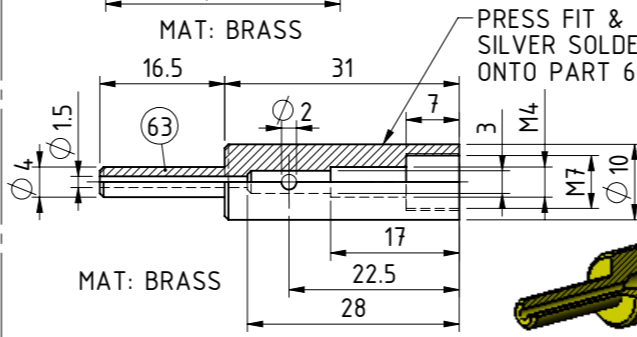
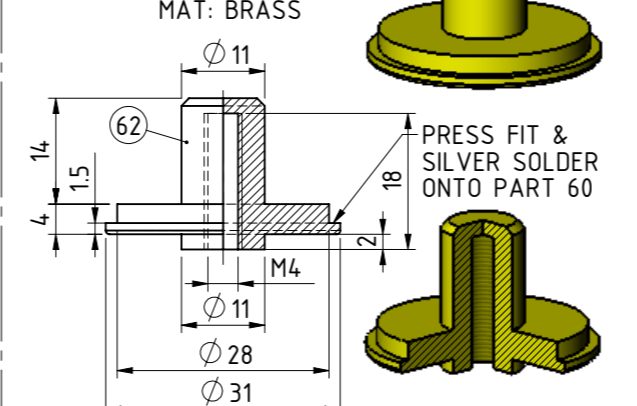
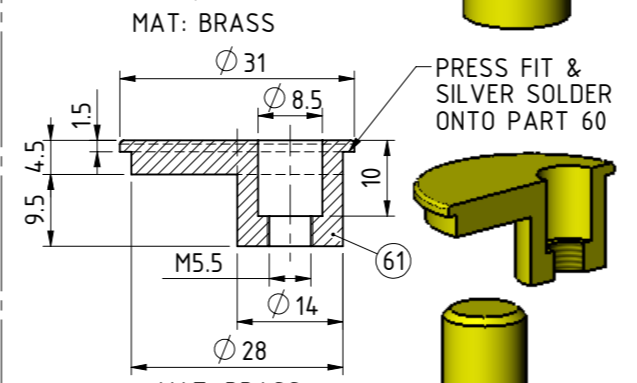
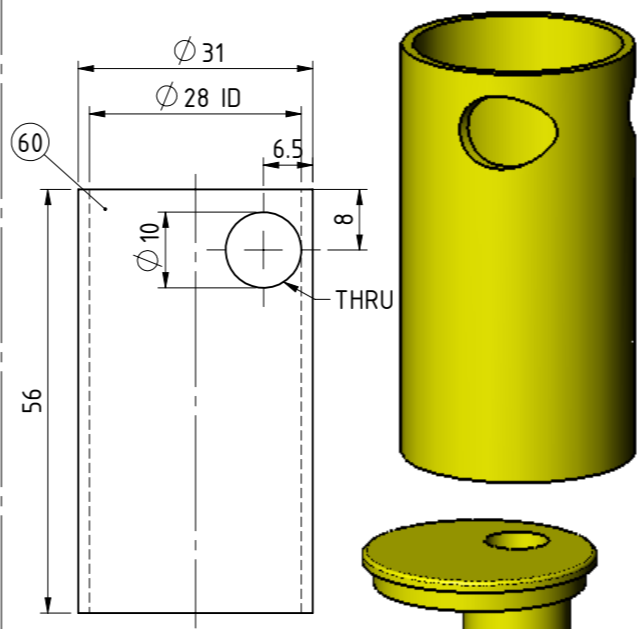

STOOM LOKOMOTIEF MET OSCILLERENDE STOOMMACINE "CRACKER" DESIGNED BY: ERNEST GLASER ONWORPEN DOOR: ERNEST GLASER CONVERTED FROM O-SCALE (32mm) TO G-SCALE (45mm) BY J.A.M. DE WAAL

TITLE  
**STEAM LOCOMOTIVE WITH OSCILATING STEAM ENGINE "CRACKER"**  
**A3 GAS BURNER & GASTANK PARTS & ASSEMBLIES**

DRAWN BY J.A.M. DE WAAL		PROJECTION 		DRAWING NUMBER CRACKER 06		SHEET 06	
DATE JULY 2009		SCALE 1:1 or AS SHOWN		CAD FILE		REV A	

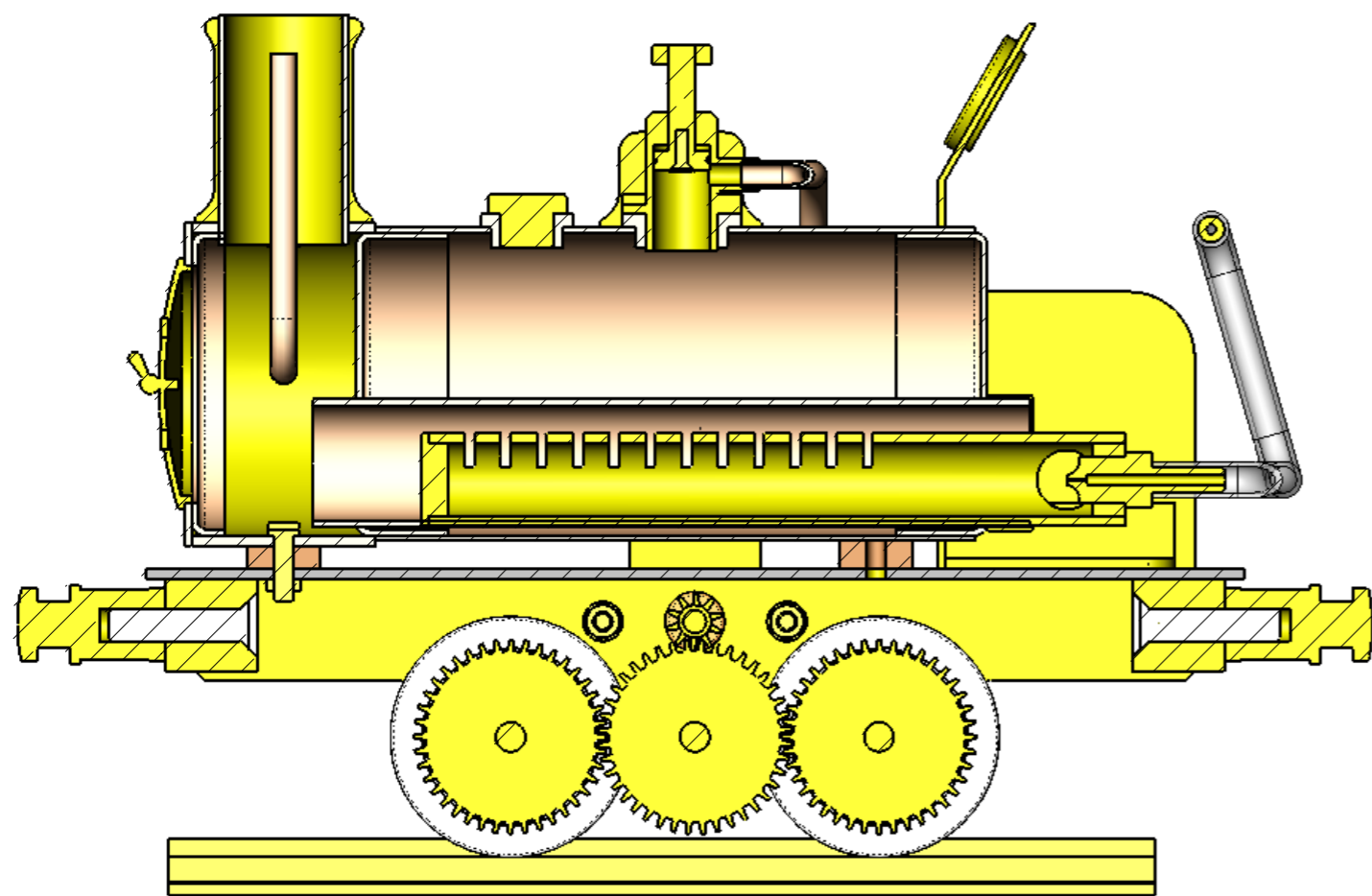

SECTION A-A  
SCALE 1 : 1.1

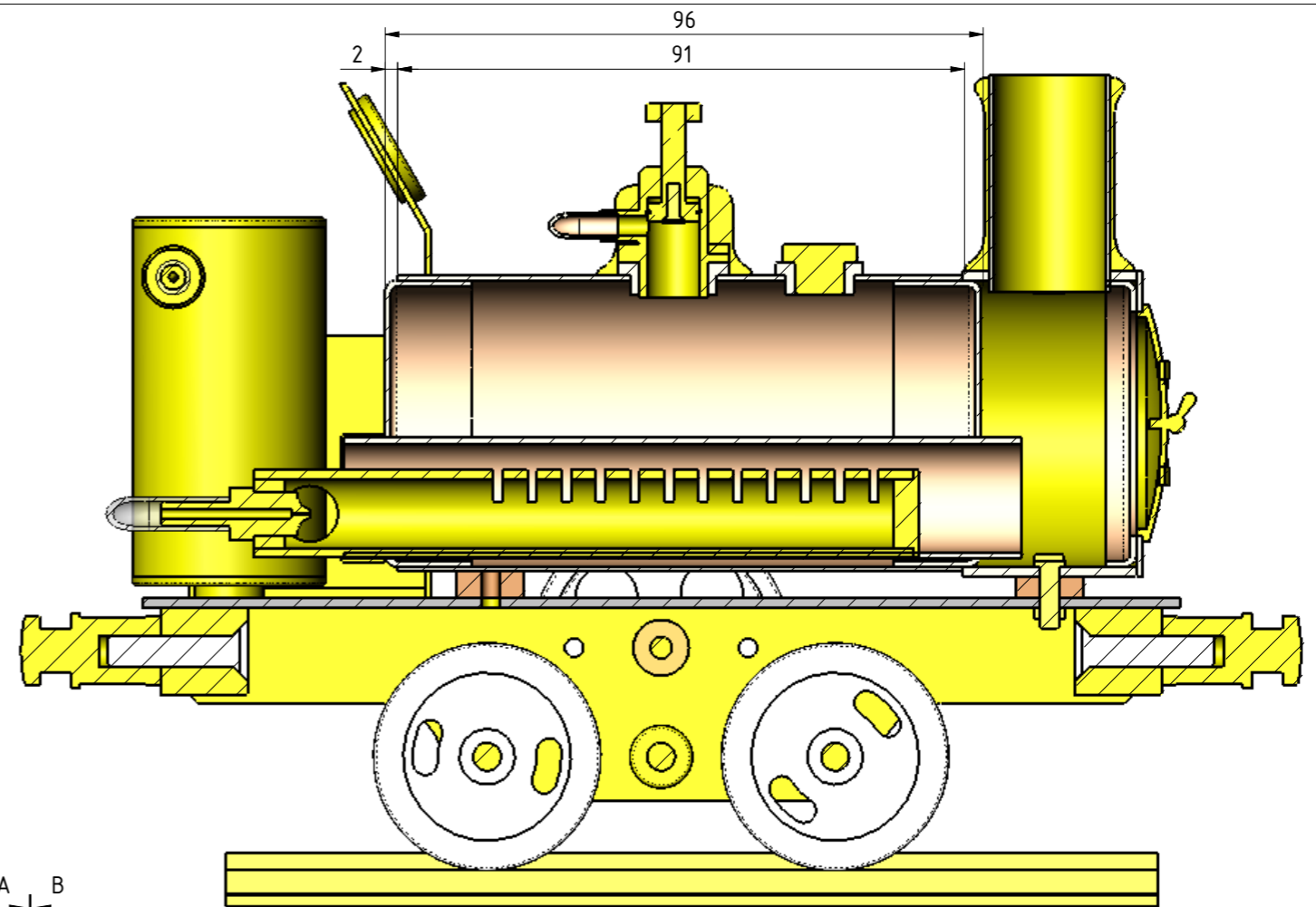

SECTION B-B  
SCALE 1 : 1.1

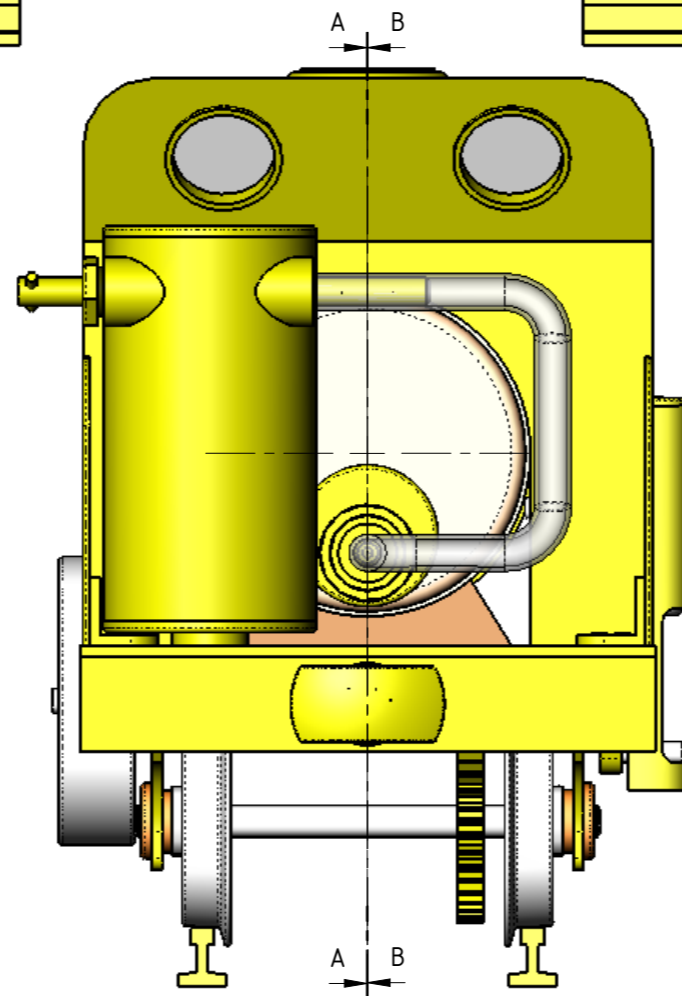

STOOM LOKOMOTIEF MET OSCILLERENDE STOOMMACINE "CRACKER" | DESIGNED BY: ERNEST GLASER | ONWORPEN DOOR: ERNEST GLASER | CONVERTED FROM O-SCALE (32mm) TO G-SCALE (45mm) BY J.A.M. DE WAAL

A3 TITLE  
**STEAM LOCOMOTIVE WITH OSCILATING STEAM ENGINE "CRACKER"**  
**GENERAL ARRANGEMENT**

ISSUED FOR CONSTRUCTION	DATE	JDW DRAUGHTING SERVICES 12 BRIGHTWELL STREET PAKAKURA NEW ZEALAND TEL/FAX 0064-09-2988815 E-MAIL:dewaal@xtra.co.nz
DESCRIPTION		

DRAWN BY J.A.M. DE WAAL	PROJECTION 	DRAWING NUMBER CRACKER	SHEET 07
DATE JULY 2009	SCALE 1:1 or AS SHOWN	CAD FILE	REV A