

QTY.	PART NUMBER
1	09E-40-01-1-01-BASE PLATE
2	09E-40-01-1-02-SUPPORT COLUMN
1	09E-40-01-1-03-SUPPORT FRAME
1	09E-40-01-1-03-SUPPORT FRAME
1	09E-40-01-1-04-BELL CRANK SHAFT+SPACERS
1	09E-40-01-1-05-CRANK BEARING PLATFORM+BEARING
1	09E-40-01-1-05-CRANK BEARING PLATFORM+BEARING
1	09E-40-01-1-06-CYLINDER+VALVE CHEST
2	09E-40-01-1-07-INLET-EXHAUST NIPPLE
1	09E-40-01-1-08-CYLINDER TOP COVER
1	09E-40-01-2-01-CRANK SHAFT
1	09E-40-01-2-02-SIDE BEAM
2	09E-40-01-2-03-SECONDARY CON-ROD
1	09E-40-01-2-04-PISTON+CROSSHEAD
2	09E-40-01-2-05-PRIMARY CON-ROD
1	09E-40-01-2-06-ECCENTRIC SHEAVE
1	09E-40-01-2-07-BELL CRANK
1	09E-40-01-2-08-ECCENTRIC STRAP
1	09E-40-01-2-09-SLIDE VALVE+ROD
11	09E-40-01-M3 NUT
4	09E-40-01-M3 WASHER BRASS
10	09E-40-01-M3x12 A-K CYL HEAD SCREW
4	09E-40-01-M3x16 A-K CYL HEAD SCREW
3	09E-40-01-M3x5 A-K GRUB SCREW
2	09E-40-01-M3x7 A-K GRUB SCREW
8	09E-40-01-M3x8 A-K CYL HEAD SCREW
8	09E-40-01-M4 DOME NUT
9	09E-40-01-M4 NUT
8	09E-40-01-M4x18 A-K CYL HEAD SCREW
2	09E-40-01-M4x26 A-K CYL HEAD SCREW
8	09E-40-01-M4x52 THREADED ROD
6	09E-40-01-M5 DOME NUT
4	09E-40-01-M5x20 A-K CYL HEAD SCREW
2	09E-40-01-M5x28 A-K CYL HEAD SCREW

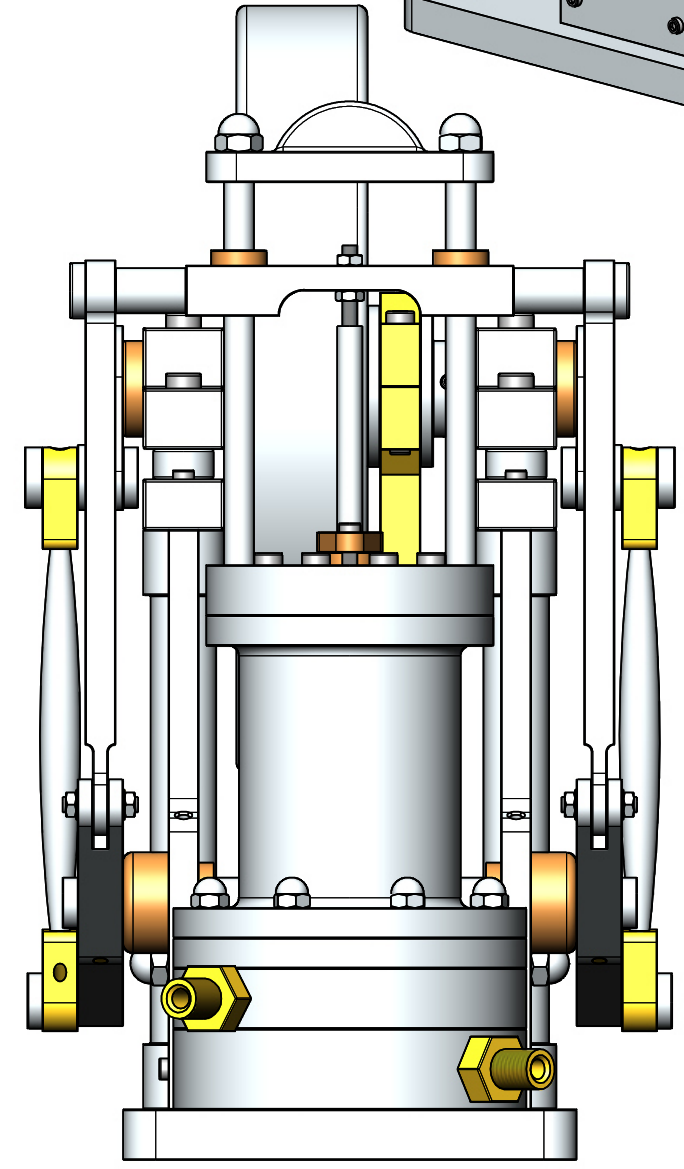
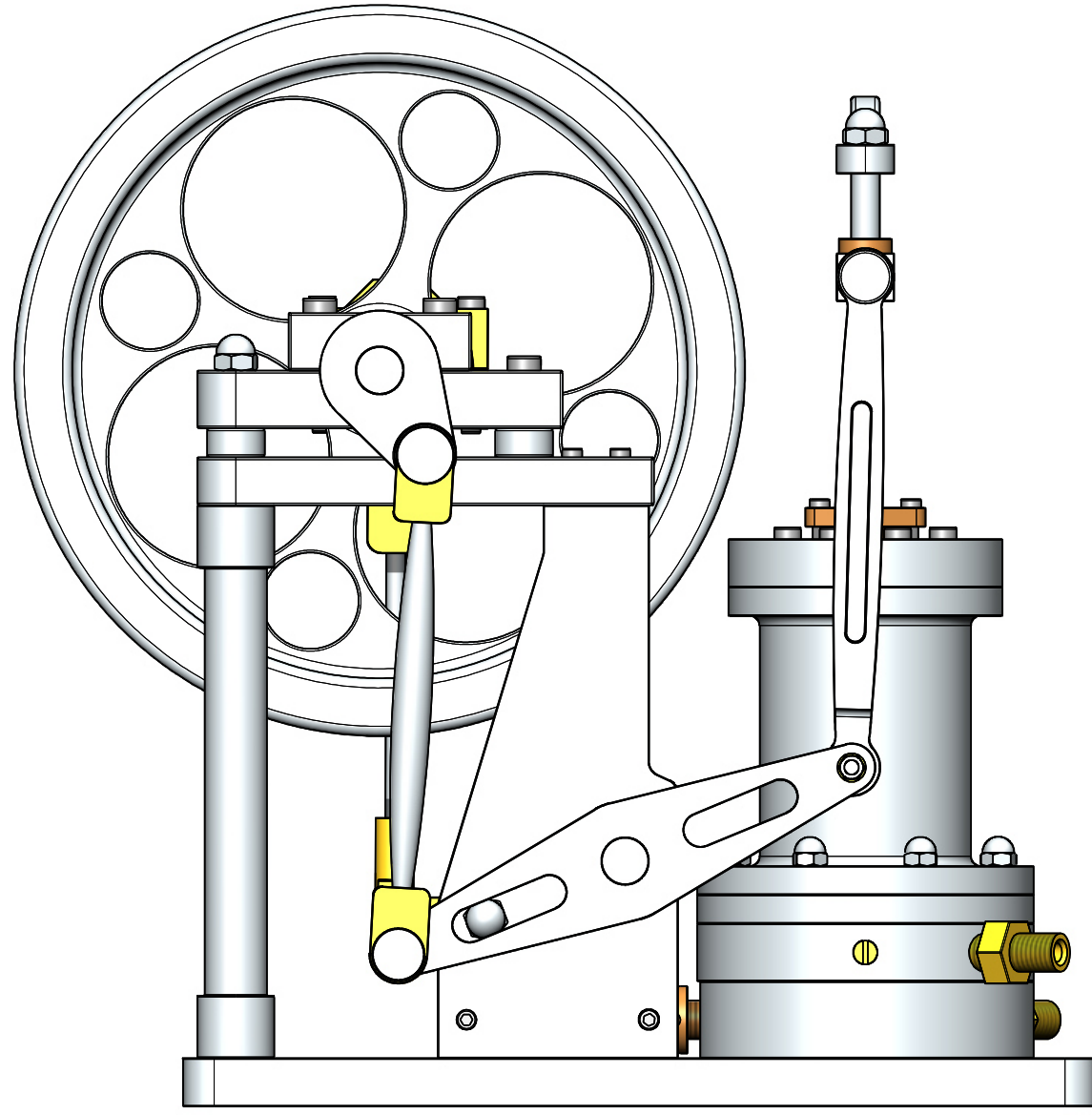
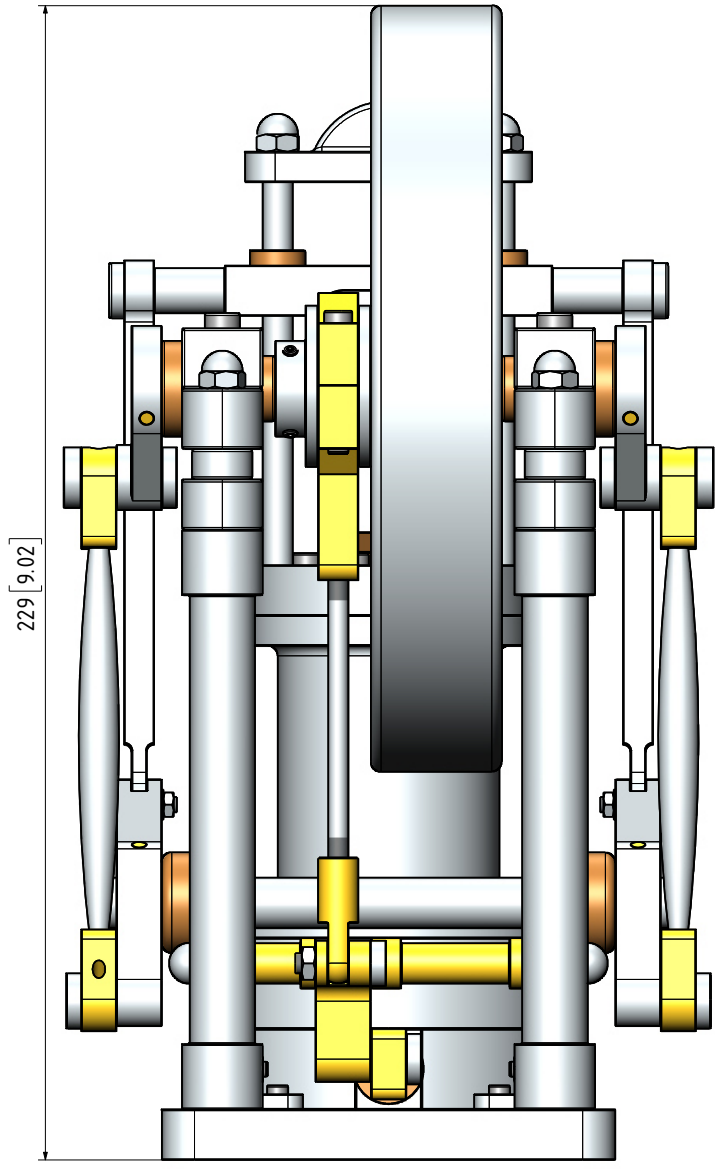
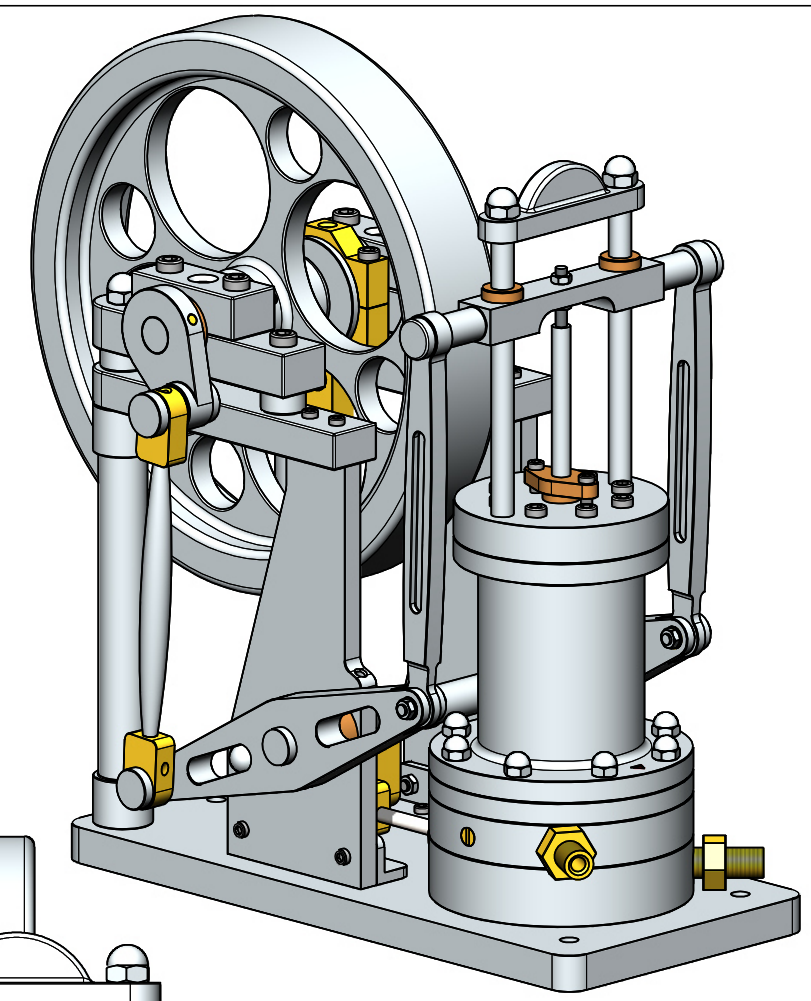
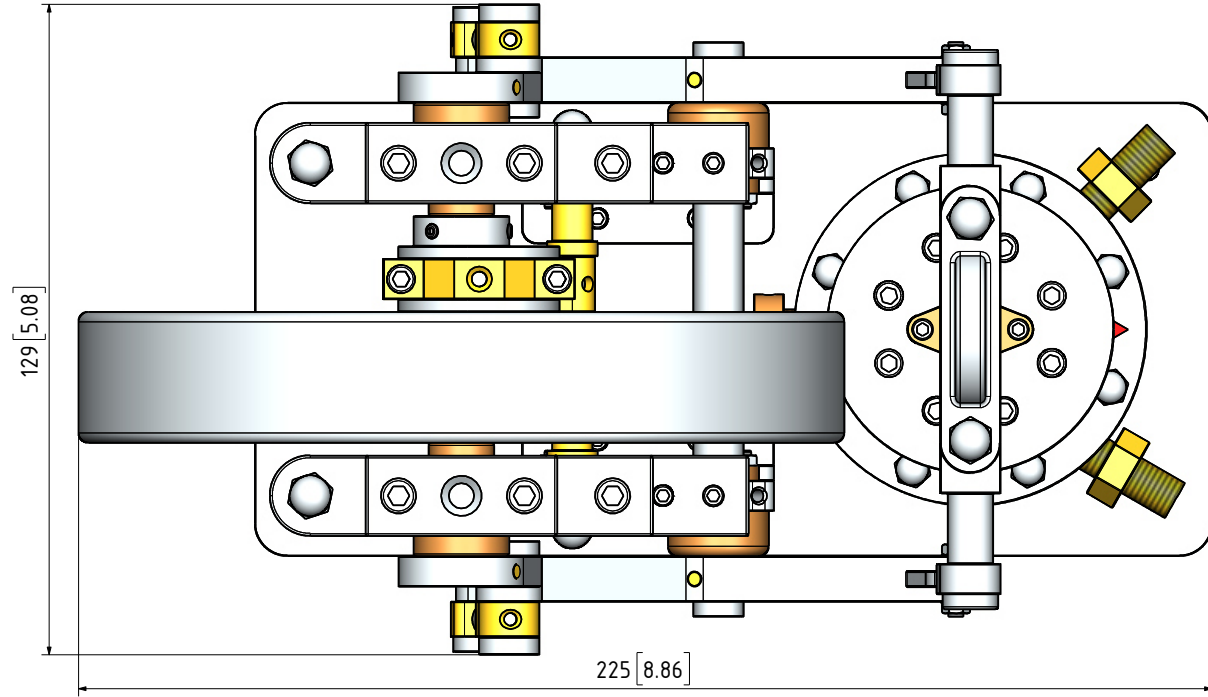

NOTES: THE ORIGINAL DESIGN DRAWINGS WERE BY BOB MIDDLETON, MUNDELEY, NORFOLK, UK. A SET OF 17 A4 DRAWINGS WERE PUBLISHED ON THE "MODELENGINEERINGWEBSITE" WEBSITE

TITLE  
**1-CYLINDER DOUBLE SIDED BEAM STEAM ENGINE CALLED "TRUNCH TROJAN" (METRIC)**

DRAWING CONTENTS  
**GENERAL ARRANGEMENT, ISOMETRIC VIEW, BILL OF MATERIALS**

PROJECT No 09E-40-01  
 JDW DRAUGHTING SERVICES  
 J.A.M. DE WAAL, 12 BRIGHTWELL STREET PAKAPURA  
 2110, NEW ZEALAND. PHONE: 0064 09 2988815. MOB: 0211791000 E-MAIL: dewaal@xtra.co.nz.

PROJECTION	<b>JDWDS</b>	MODEL SCALE: 1:1
DATE	MARCH 2020	DWG SCALE: 1:1 @A3 OR AS SHOWN
SHEET: 01 OF 04		Copyright © J.A.M. DE WAAL PAKAPURA NZ
A3		No: 09E-40-01-SHT01

**DRAWINGS ARE FOR PERSONAL USE ONLY NOT FOR COMMERCIAL PURPOSES**

NOTES:  
 0. ALL DRAWINGS ARE IN METRIC MEASUREMENTS  
 1. ALL ENGINEERING PRACTICES SHALL BE APPLIED WITH REGARDS TO HOLE AND SHAFT TOLERANCES.  
 2. WHERE SCREWS OR BOLTS ARE USED THE CLEARANCE HOLES SHALL BE APPROXIMATELY 5% TO 8% LARGER THAN THE MATCHING TAPPED HOLE.  
 3. PREFERABLY ALL TAPPED HOLES AND MATCHING SCREWS AND/OR BOLTS TO BE METRIC FINE (MF)  
 4. MATERIALS SPECIFIED ON THE DRAWINGS ARE INDICATIVE ONLY. THE BUILDER CAN MAKE HIS/HER OWN MATERIAL CHOICE.  
 5. ALL CONNECTIONS/JOINTS WHICH HAVE STEAM PRESSURE APPLIED TO IT SHALL BE SILVER/HARD SOLDERED.  
 6. COMPRESSION SPRINGS ARE DRAWN IN COMPRESSED STATE (CP), UNCOMPRESSED STATE IS APPROX 40% TO 60% LONGER THEN COMPRESSED STATE.  
 7. WHERE PREFERRED SCREW OR RIVETED CONNECTIONS CAN BE OMITTED AND PARTS CAN BE BONDED TOGETHER BY USING EITHER HIGH STRENGTH GLUE, EPOXY RESIN, OR SOLDER.  
 8. PARTS WHICH ARE DIRECTLY EXPOSED TO STEAM AND/OR WATER SHOULD BE CONSTRUCTED USING NON-FERROUS OR NON CORROSIVE MATERIAL SUCH AS BRASS, BRONZE, GUNMETAL, STAINLESS STEEL, COPPER OR MONEL.  
 9. THE ORDER IN WHICH THE PARTS/COMPONENTS ARE MANUFACTURED AND THE MODEL IS ASSEMBLED IS ENTIRELY LEFT TO THE BUILDER/MODEL MAKER.  
 10. A COLOUR SCHEME FOR THIS PROJECT IS ENTIRELY LEFT UP TO THE MODEL MAKER.  
 11. THE MANNER IN WHICH THE PARTS/COMPONENTS ARE MANUFACTURED IS ENTIRELY LEFT UP TO THE BUILDER.  
 12. USE LOCTITE, ON SCREW OR PRESS FIT CONNECTIONS OR SURFACES, WERE DEEMED NECESSARY TO PREVENT PARTS FROM LOOSENING.  
 13. WASHERS AND/OR SPRINGWASHERS SHALL BE USED WHERE DEEMED NECESSARY.  
 XX. ERRORS AND/OR OMISSIONS MAY OCCUR IN THE DRAWINGS, DO NOT HESITATE TO CONTACT ME SO THAT THE ERRORS/OMISSIONS CAN BE RECTIFIED.

**OTHER ABBREVIATIONS**  
 AS = AS SHOWN  
 DP = DEEP  
 DAA= DRILL AFTER ASSEMBLY  
 D&TAA= DRILL AND TAP AFTER ASSEMBLY  
 CF = CLOSE FIT (SIZE FOR SIZE)  
 PF = PRESS FIT  
 PFAA= PRESS FIT AFTER ASSEMBLY  
 PCD = PITCH CIRCLE DIAMETER  
 RM = REAM  
 HEX = HEXACON, 6SIDED  
 CP = COMPRESSED  
 KNL = KNURLED  
 CSK = COUNTERSINK  
 PL = PLACES  
 DWL= DOWEL  
 SPF= SPOTFACE  
 (T)HESOP=(TAPPED)HOLES EQUALLY SPACED ON PCD  
 (T)HESOC=(TAPPED)HOLES EQUALLY SPACED ON CIRCUMFERENCE  
 OD = OUTSIDE DIAMETER  
 ID = INSIDE DIAMETER  
 [SA-xxx]= SUB ASSEMBLY-xxx

**MATERIAL ABBREVIATIONS:**  
 ALU = ALUMINIUM  
 HALU= HARD ALUMINIUM  
 BRS = BRASS  
 BRZ = BRONZE OR GUNMETAL (BRZ/GM)  
 CI = CAST IRON  
 CU = COPPER  
 GRA = GRAPHITE  
 MS = MILD STEEL/BRIGHT MILD STEEL  
 SS = SILVER STEEL OR STAINLESS STEEL  
 SPS = SPRING STEEL  
 PEEK= POLYETHER ETHER KETONE  
 SYN = SYNTHETIC MATERIAL SUCH AS VETON, NYLON, TEFLON OR RUBBER  
 IN GENERAL SYNTHETIC MATERIALS SHOULD BE ABLE TO WITHSTAND THE HEAT AND PRESSURE(S) APPLIED TO THEM.  
 nnn/nnn MEANS THAT EITHER MATERIAL CAN BE USED

THE OFF SET ANGLE OF THE ECCENTRIC IN RELATION TO THE CRANK AXIS TO BE EXPERIMENTALLY DETERMINED FOR THE SMOOTH RUNNING OF THE ENGINE AND SATISFACTION OF THE BUILDER

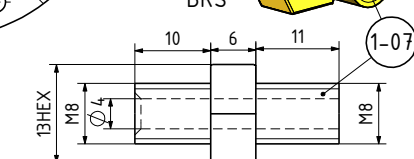
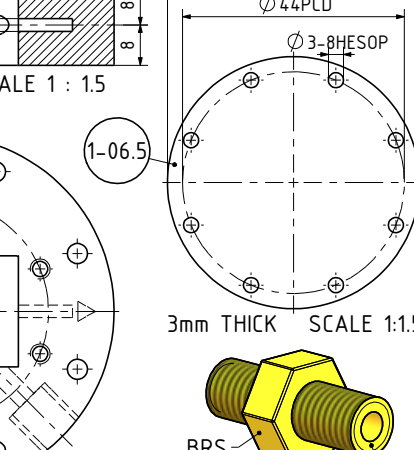
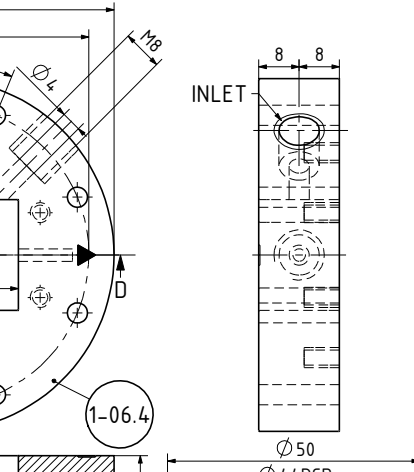
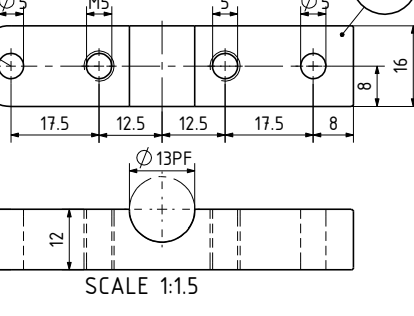
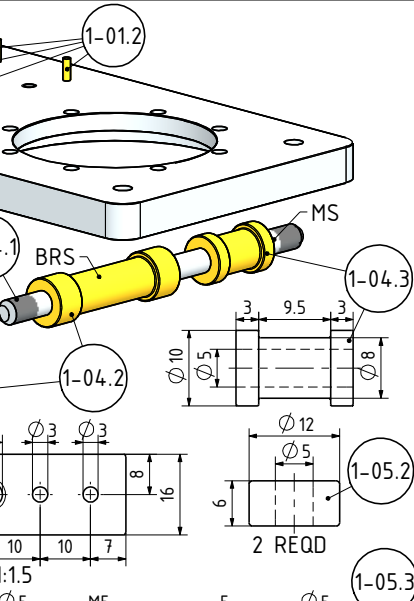
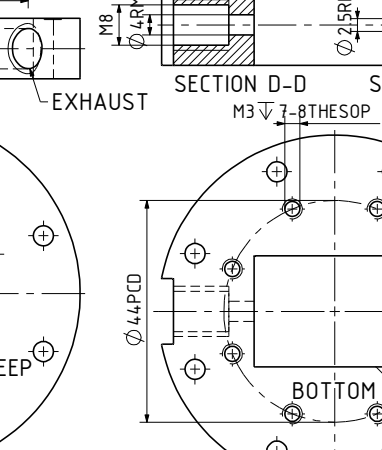
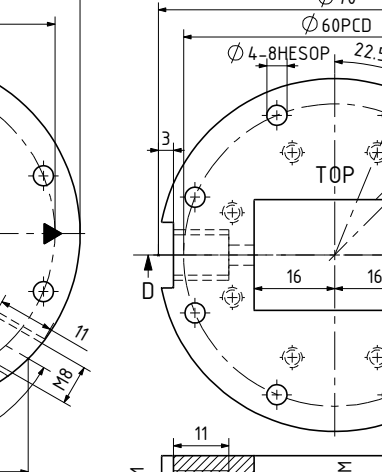
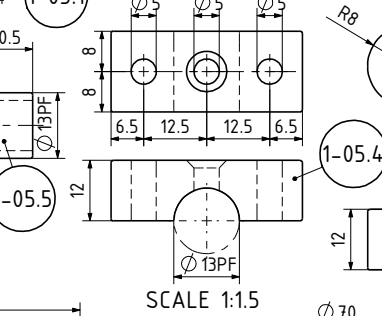
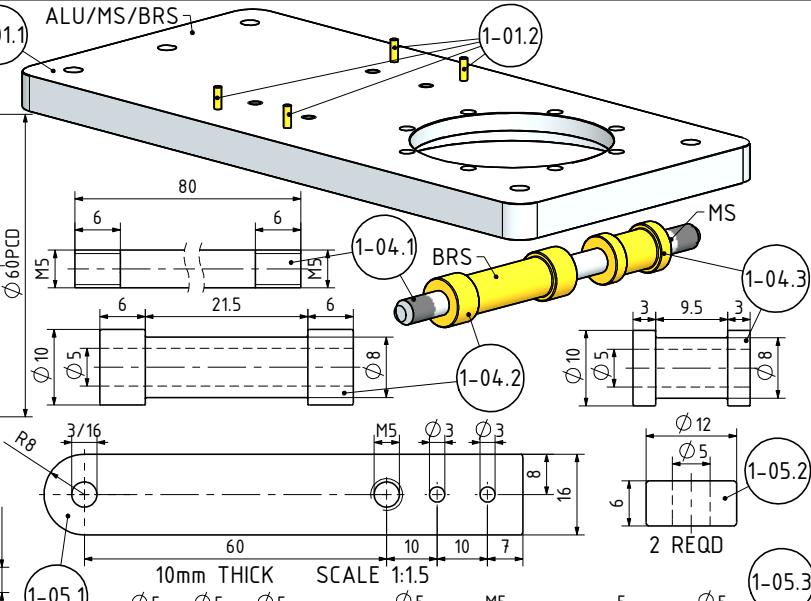
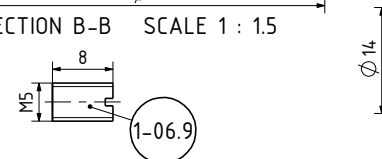
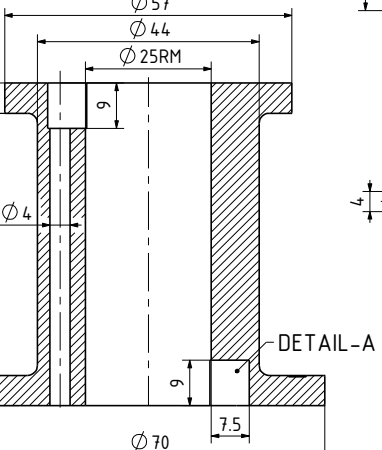
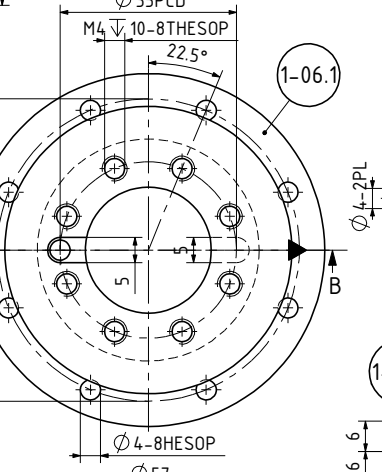
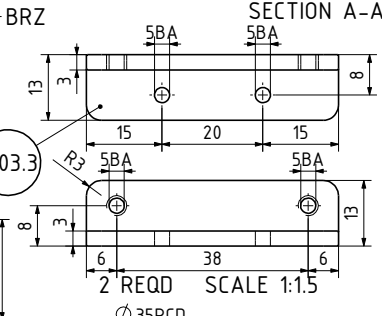
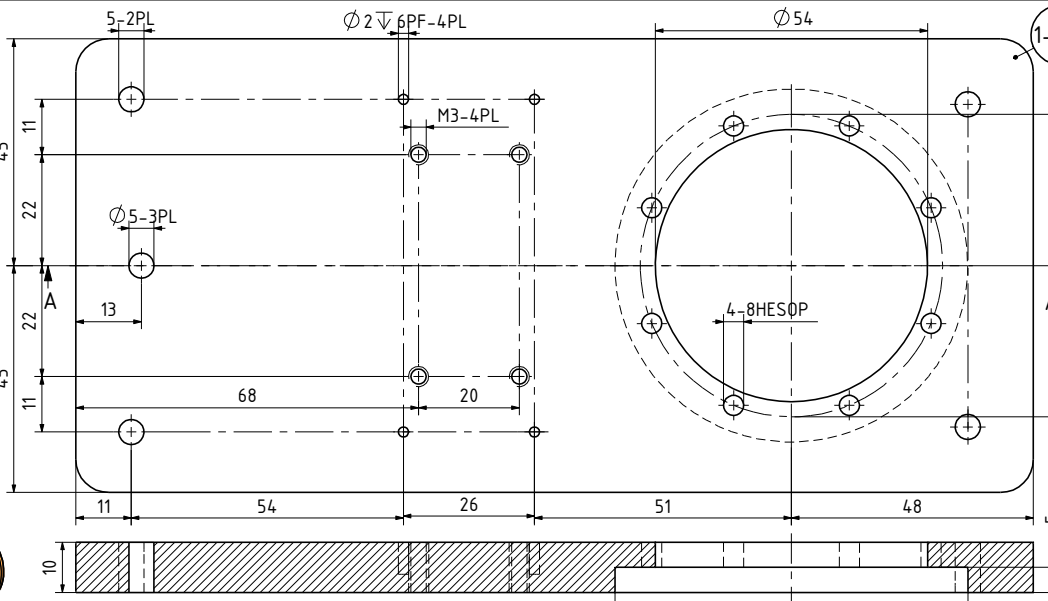
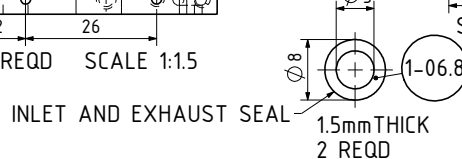
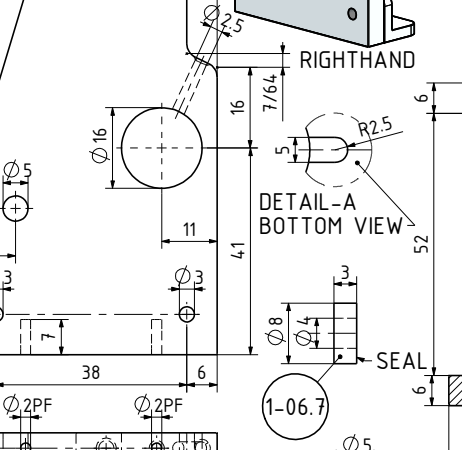
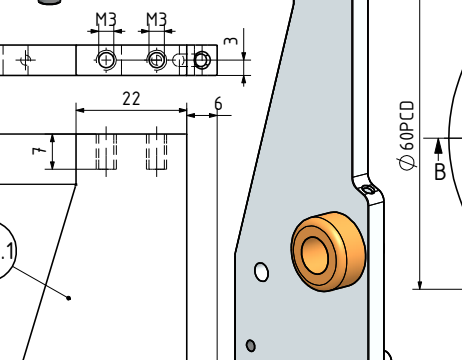
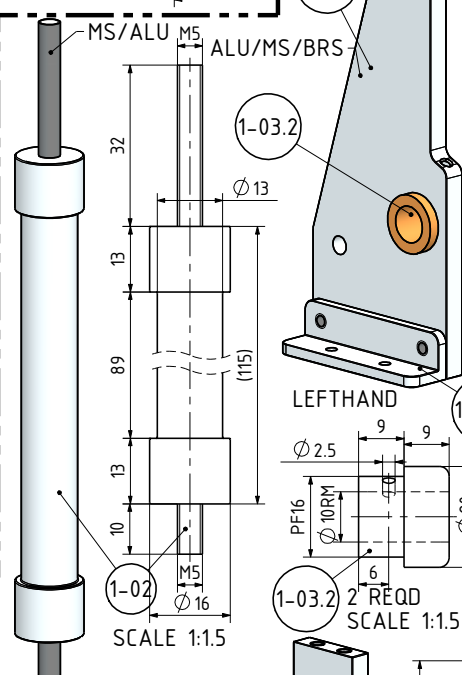
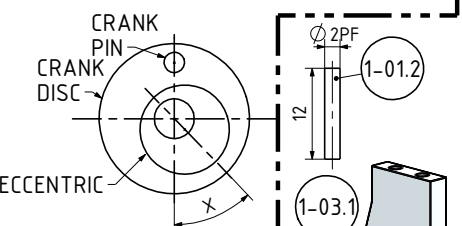

NOTES: THE ORIGINAL DESIGN DRAWINGS WERE BY BOB MIDDLETON, MUNDELEY, NORFOLK, UK. A SET OF 17 A4 DRAWINGS WERE PUBLISHED ON THE "MODELENGINEERINGWEBSITE" WEBSITE

TITLE  
**1-CYLINDER DOUBLE SIDED BEAM STEAM ENGINE CALLED "TRUNCH TROJAN" (METRIC)**

DRAWING CONTENTS  
**NOTES, PARTS AND ASSEMBLIES**

PROJECT No 09E-40-01  
 JDW DRAUGHTING SERVICES  
 J.A.M. DE WAAL, 12 BRIGHTWELL STREET PAPAOKURA  
 2110, NEW ZEALAND. PHONE: 0064 09 2988815. MOB: 0211791000 E-MAIL: dewaal@xtra.co.nz.

PROJECTION  
**JDWDS**  
 MODEL SCALE: 1:1  
 DWG SCALE: 1:1 @A3 OR AS SHOWN  
 DATE MARCH 2020 Copyright © J.A.M. DE WAAL PAPAOKURA NZ  
 SHEET: 02 OF 04 **A3** No: 09E-40-01-SHT02

**DRAWINGS ARE FOR PERSONAL USE ONLY NOT FOR COMMERCIAL PURPOSES**

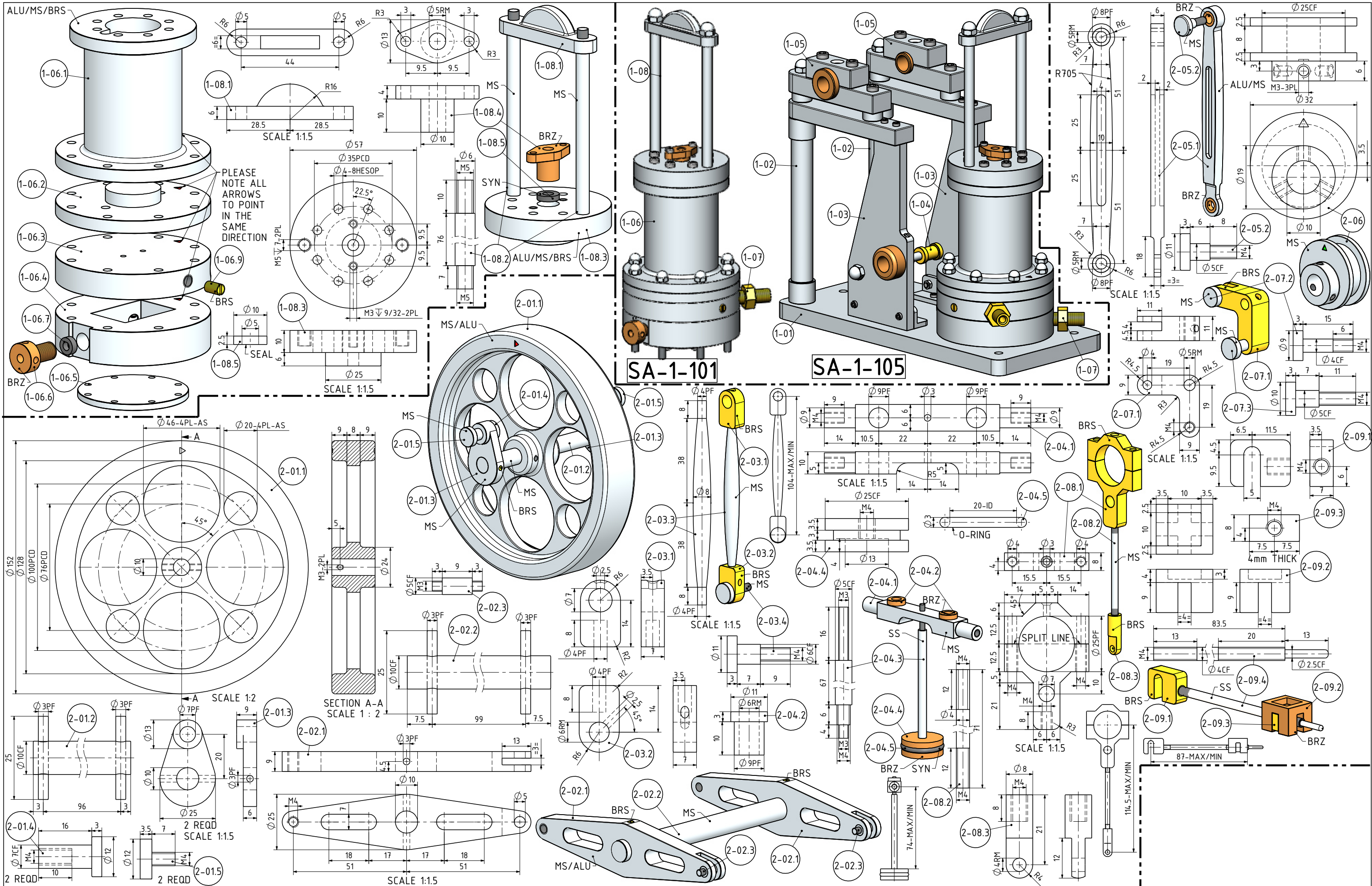

NOTES: THE ORIGINAL DESIGN DRAWINGS WERE BY BOB MIDDLETON, MUNDELEY, NORFOLK, UK. A SET OF 17 A4 DRAWINGS WERE PUBLISHED ON THE "MODELENGINEERINGWEBSITE" WEBSITE

TITLE  
**1-CYLINDER DOUBLE SIDED BEAM STEAM ENGINE CALLED "TRUNCH TROJAN" (METRIC)**

DRAWING CONTENTS  
**PARTS AND ASSEMBLIES**

PROJECT No 09E-40-01  
 JDW DRAUGHTING SERVICES  
 J.A.M. DE WAAL, 12 BRIGHTWELL STREET PAPAOKURA  
 2110, NEW ZEALAND. PHONE: 0064 09 2988815. MOB: 0211791000 E-MAIL: dewaal@xtra.co.nz.

PROJECTION **JDWDS** MODEL SCALE: 1:1  
 DWG SCALE: 1:1 @A3 OR AS SHOWN  
 DATE MARCH 2020 Copyright © J.A.M. DE WAAL PAPAOKURA NZ  
 SHEET: 03 OF 04 **A3** No: 09E-40-01-SHT03

**DRAWINGS ARE FOR PERSONAL USE ONLY NOT FOR COMMERCIAL PURPOSES**

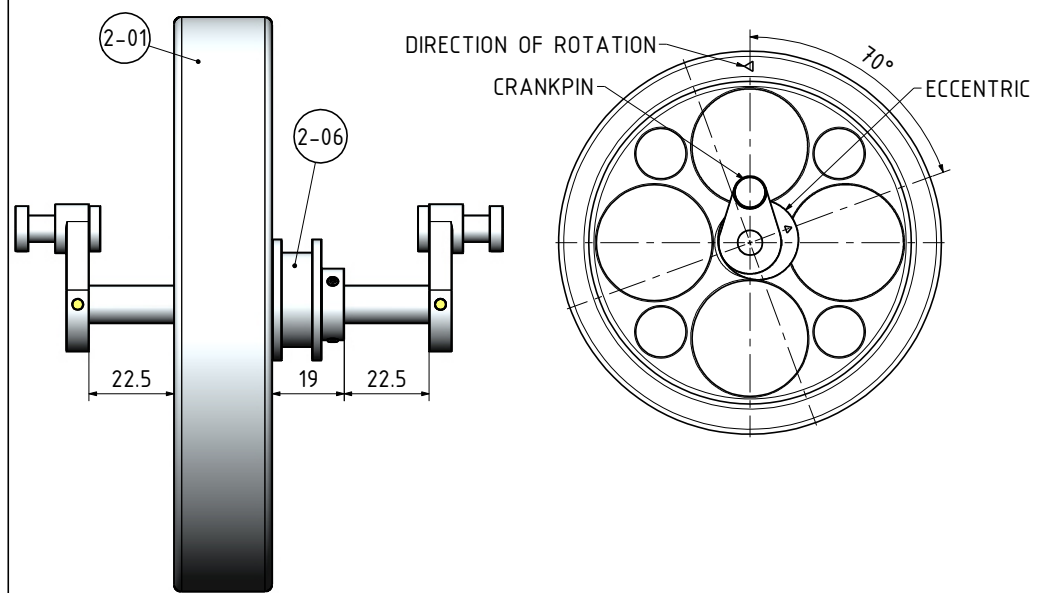

SA-2-201

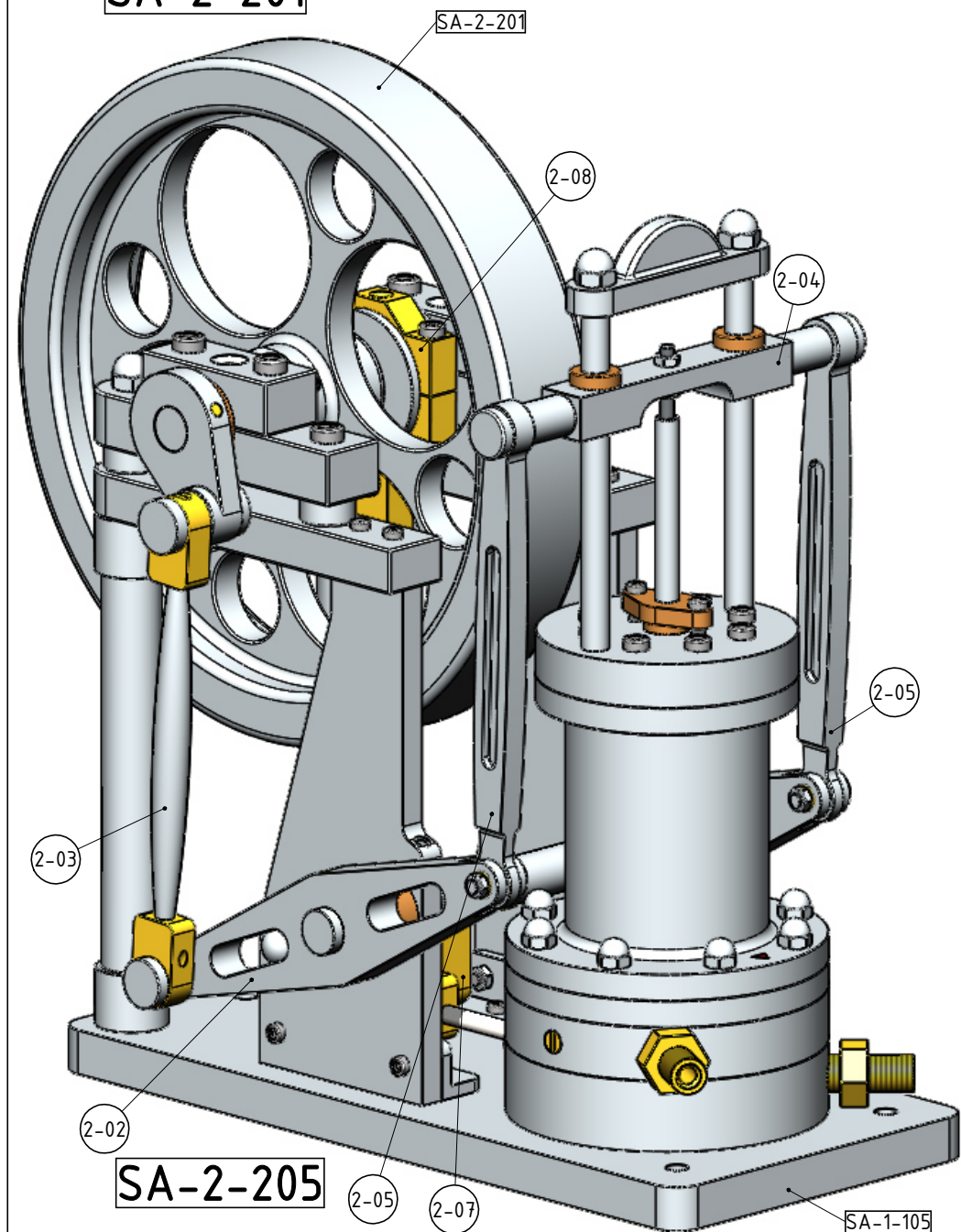

SA-2-205

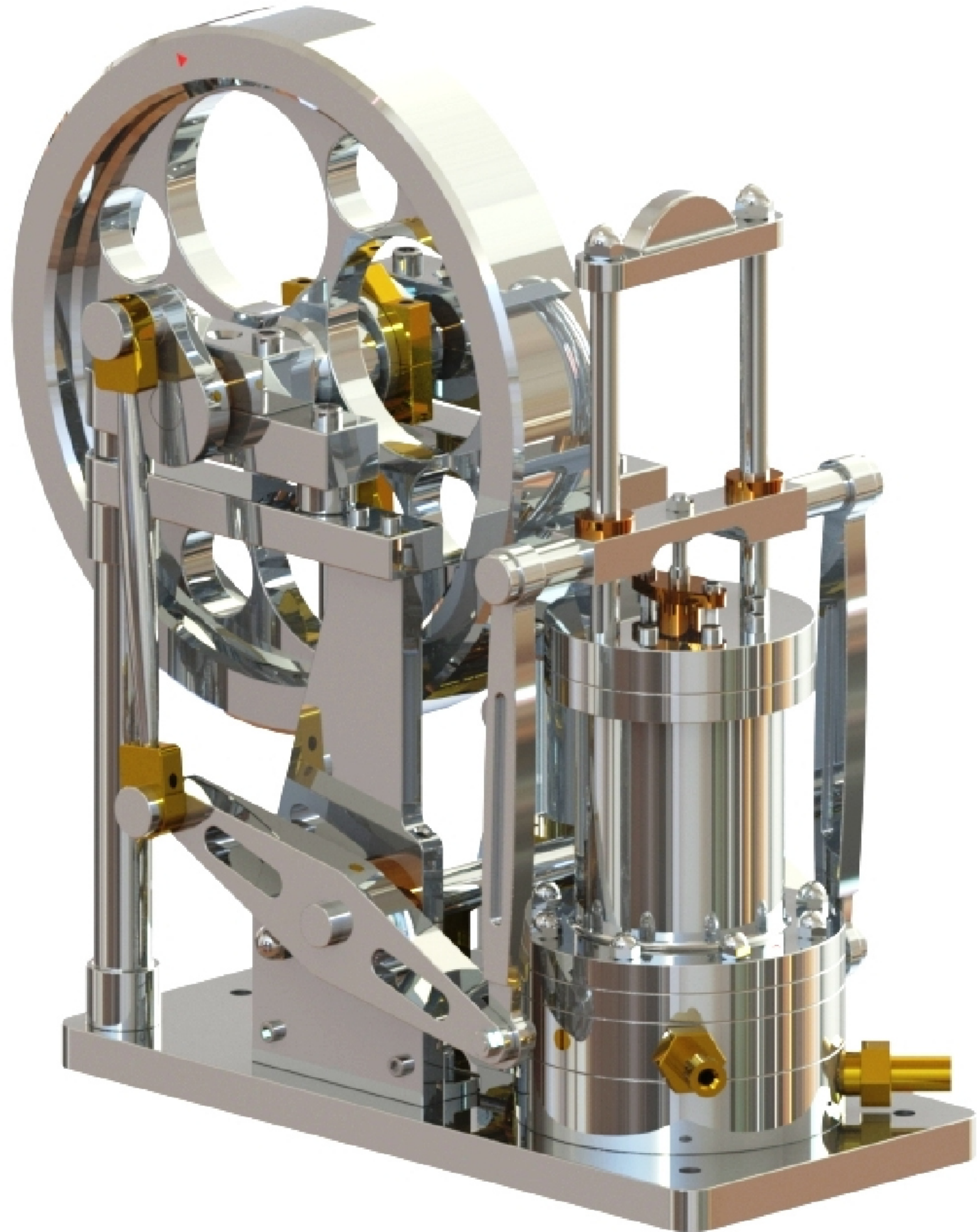

NOTES: THE ORIGINAL DESIGN DRAWINGS WERE BY BOB MIDDLETON, MUNDELEY, NORFORK, UK. A SET OF 17 A4 DRAWINGS WERE PUBLISHED ON THE "MODELENGINEERINGWEBSITE" WEBSITE

TITLE  
**1-CYLINDER DOUBLE SIDED BEAM STEAM ENGINE CALLED "TRUNCH TROJAN" (METRIC)**

DRAWING CONTENTS  
**PARTS AND ASSEMBLIES, RENDERED PICTURE**

PROJECT No 09E-40-01  
 JDW DRAUGHTING SERVICES  
 J.A.M. DE WAAL, 12 BRIGHTWELL STREET PAPA KURA  
 2110, NEW ZEALAND. PHONE: 0064 09 2988815. MOB:  
 0211791000 E-MAIL: dewaal@xtra.co.nz.

PROJECTION	<b>JDWDS</b>	MODEL SCALE: 1:1
DATE	MARCH 2020	DWG SCALE: 1:1 @A3 OR AS SHOWN
SHEET: 04 OF 04		Copyright © J.A.M. DE WAAL PAPA KURA NZ
A3		No: 09E-40-01-SHT04

**DRAWINGS ARE FOR PERSONAL USE ONLY NOT FOR COMMERCIAL PURPOSES**