

QTY.	PART NUMBER
1	45DSTE-01-BASE PLATE
1	45DSTE-02-MAIN FRAME
1	45DSTE-03-CYLINDER
1	45DSTE-04-PISTON
1	45DSTE-05-CRANK SHAFT
1	45DSTE-06-CRANK WHEEL
1	45DSTE-07-CRANK PIN
1	45DSTE-08-FLYWHEEL
1	45DSTE-09-AIR HOSE COUPLING
1	45DSTE-10-SPRING
1	45DSTE-M2.5x6 GRUB SCREW
1	45DSTE-M6 NUT
3	45DSTE-M6 WASHER
1	45DSTE-M6x12 ALLEN KEY
1	45DSTE-M6x40 ALLEN KEY

45 GRADEN EEN CILINDER OSCILLERENDE STOOMMACHINE (ALGEMEEN OVERZICHT)

THIS ENGINE WAS DESIGNED BY PROF N McCABE COUNTY COLLEGE OF MORRIS MEC-117, AMAREICA DATE 25-OCT-2005

TITLE
45DEG SINGLE CYLINDER OSCILLATING STEAM ENGINE
A3 GENERAL ARRANGEMENT

			JDW DRAUGHTING SERVICES 12 BRIGHTWELL STREET PAKAKURA NEW ZEALAND TEL/FAX 0064-09-2988815 E-MAIL:dewaal@xtra.co.nz
A	ISSUED TO NVM		
REV	DESCRIPTION	DATE	

DRAWN BY
J.A.M. DE WAAL
 DATE
 JUNE 2009

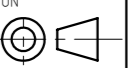
PROJECTION

 SCALE
 N.T.S.

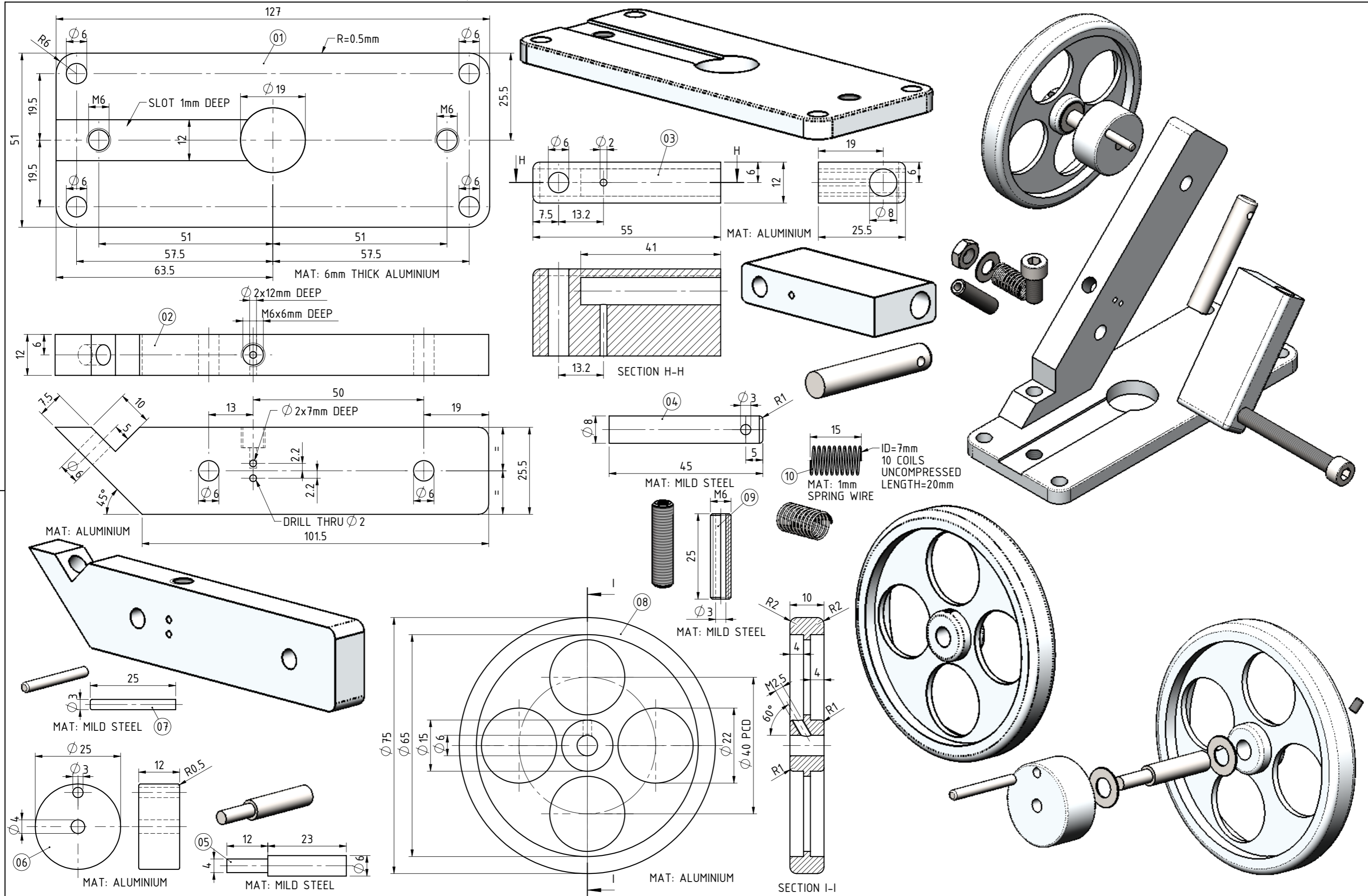
DRAWING NUMBER
45DEG
 SHEET
00
 CAD FILE
 REV
A



45 GRADEN EEN CILINDER OSCILLERENDE STOOMMACHINE (ONDERDELEN)		THIS ENGINE WAS DESIGNED BY PROF N McCABE COUNTY COLLEGE OF MORRIS MEC-117, AMAREICA DATE 25-OCT-2005			
TITLE	45DEG SINGLE CYLINDER OSCILLATING STEAM ENGINE	JDW DRAUGHTING SERVICES 12 BRIGHTWELL STREET PAPAOKURA NEW ZEALAND TEL/FAX 0064-09-2988815 E-MAIL:dewaal@xtra.co.nz		DRAWN BY J.A.M. DE WAAL	PROJECTION
A3	PARTS	A ISSUED TO NVM		DATE JUNE 2009	DRAWING NUMBER 45DEG
IF NOT STATED ALL CHAMFERS AND FILLETS 0.25mm		REV DESCRIPTION DATE		SCALE 1:1 or AS SHOWN	SHEET 01
					REMOVE ALL BURS AND SHARP EDGES