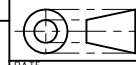

NOTES: THIS ENGINE IS BASED ON AN EARLIER PROJECT (03-18-00) WHICH WAS DRAWN UP IN OCTOBER 2019. THIS ENGINE SHOWN ON THESE DRAWINGS IS A CONVERSION FROM 3.5"/89mm TO 7.5"/190.5mm GAUGE

TITLE
DIESEL-ELECTRIC LOCOMOTIVE OF THE BRITISH RAILWAYS CLASS 08. (7.5"/190.5 GAUGE)

DRAWING CONTENTS
GENERAL ARRANGEMENT, TOP VIEW, FRONT VIEW AND SIDE VIEW

PROJECT No 03-18-01
 JDW DRAUGHTING SERVICES
 J.A.M. DE WAAL, 12 BRIGHTWELL STREET PAKAPURA
 2110, NEW ZEALAND. PHONE: 0064 09 2988815. MOB:
 0211791000 E-MAIL: dewaal@xtra.co.nz.

PROJECTION

JDWDS
 DATE MAY 2023
 SHEET: 01 OF 09

MODEL SCALE: 1:7.5
 DWG SCALE: 1:1 @A2 OR AS SHOWN
 Copyright © J.A.M. DE WAAL PAKAPURA NZ
 A2 No: 03-18-01-SHT-01

PLEASE NOTE THIS IS AN "A2" SIZE SHEET

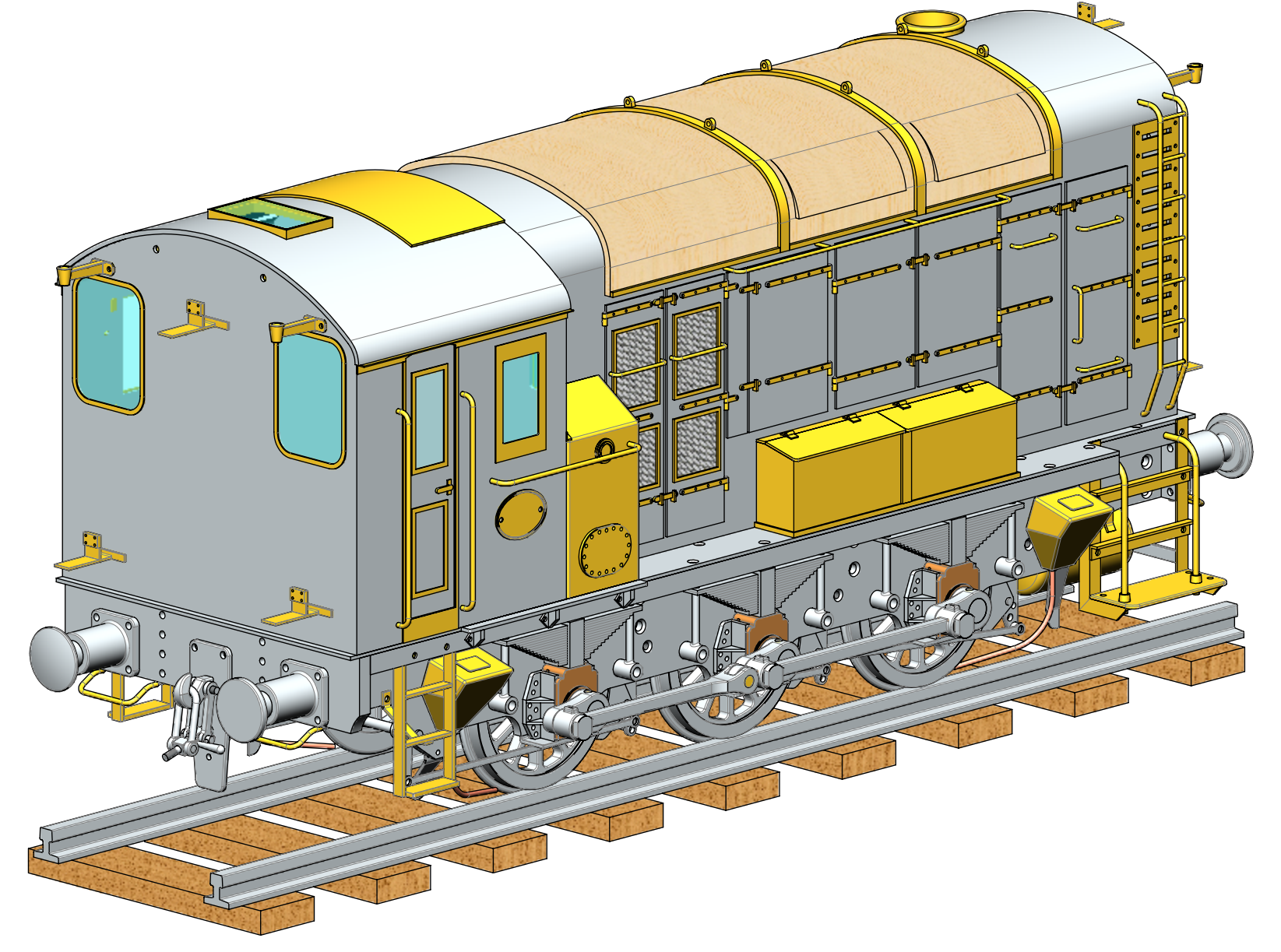
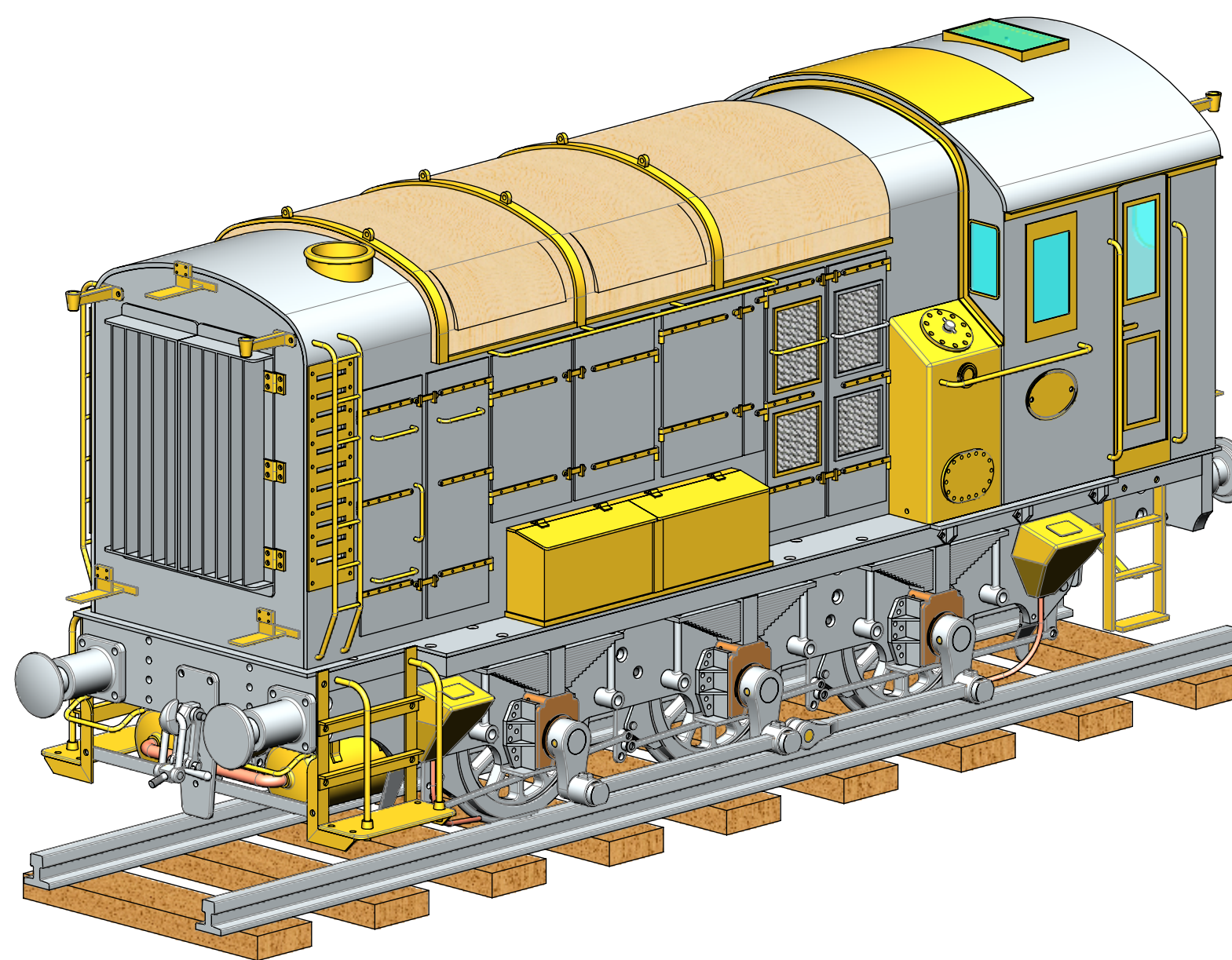
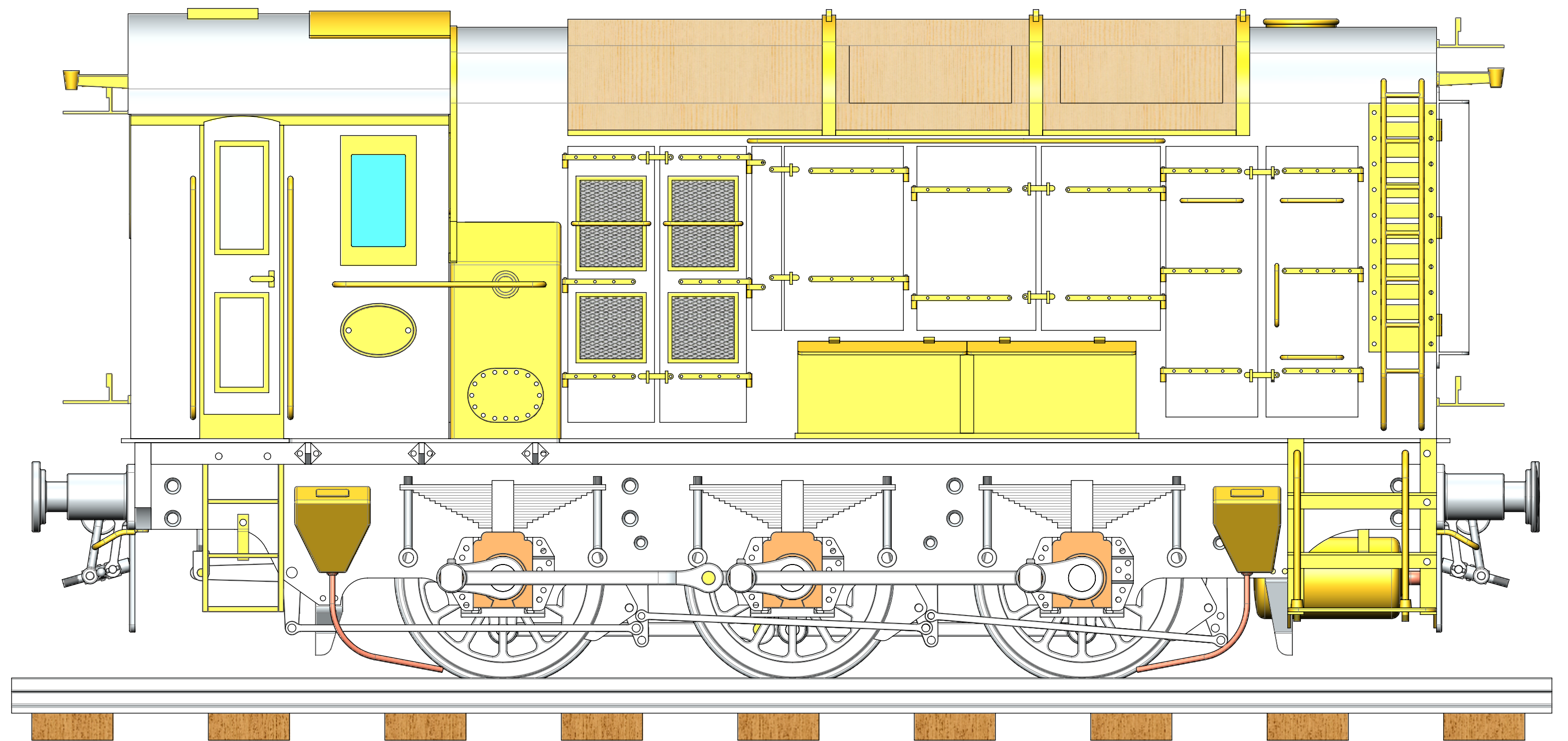
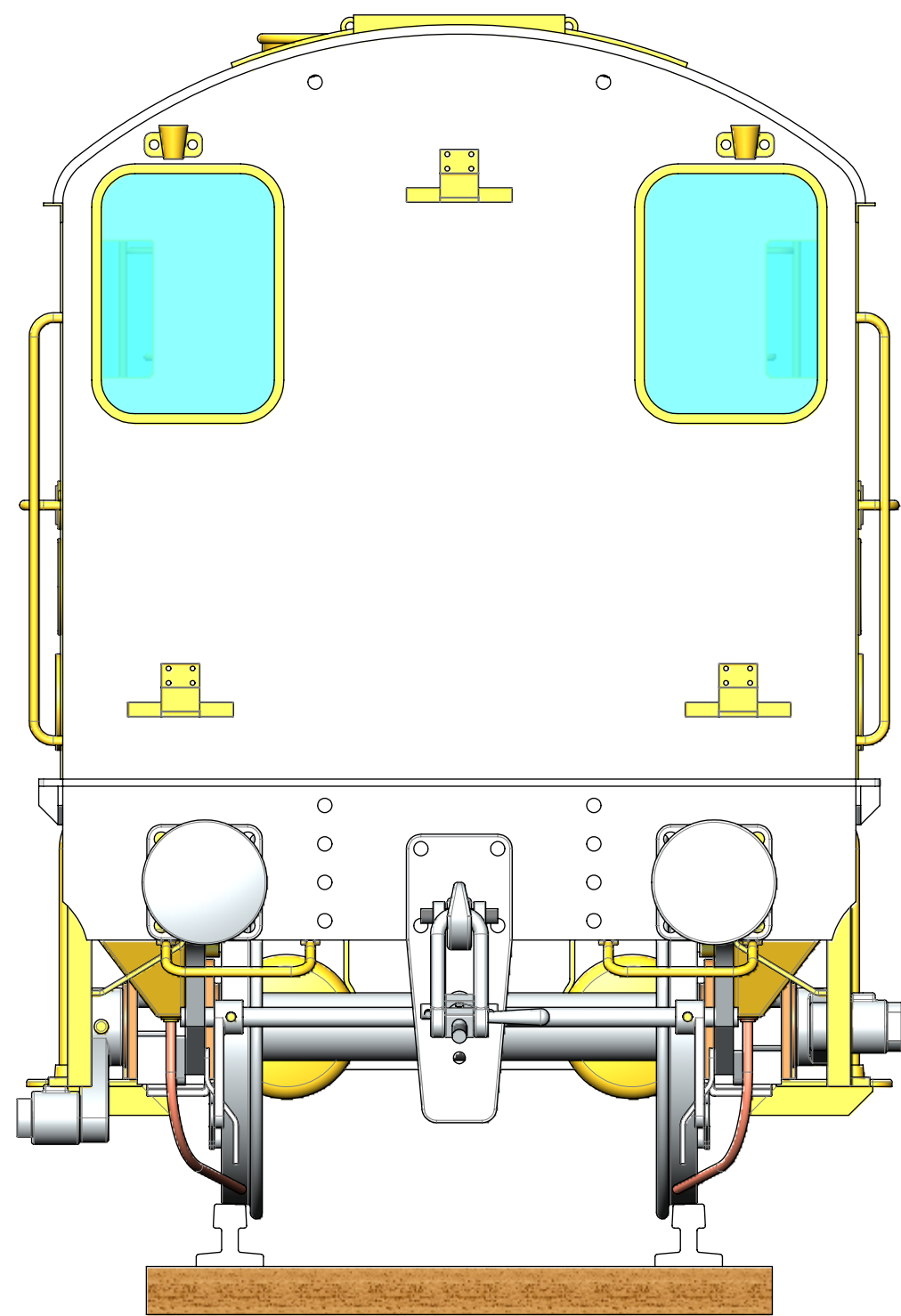
DRAWINGS ARE FOR PERSONAL USE ONLY NOT FOR COMMERCIAL PURPOSES



QTY.	PART NUMBER	QTY.	PART NUMBER
1	03-18-01-1-01-UNDER FRAME	2	03-18-01-1-40-HOOD TOP HAND RAIL
9	03-18-01-1-02-AXLE BOX GUIDE	1	03-18-01-1-41-DRIVERS CABIN
3	03-18-01-1-02-AXLE BOX GUIDE	1	03-18-01-1-42-DRIVERS CABIN DOOR
6	03-18-01-1-03-AXLE BOX LEAF-SPRING	1	03-18-01-1-43-DRIVERS CABIN ROOF
6	03-18-01-1-04-AXLE BOX	1	03-18-01-1-44-CABIN SIDE HAND RAIL
2	03-18-01-1-05-BUFFER TYPE-1	2	03-18-01-1-45-CABIN DOOR HAND RAIL
2	03-18-01-1-06-BUFFER TYPE-2	4	03-18-01-1-46-NUMBER SHIELD
2	03-18-01-1-07-PULL HOOK	2	03-18-01-2-01-WHEEL AXLE
2	03-18-01-1-08-COUPLING HOOK	3	03-18-01-2-02-COUPLING ROD
4	03-18-01-1-09-COUPLING LINK	2	03-18-01-2-03-BRAKE SHOE HANGER
2	03-18-01-1-10-SCREW SPINDLE NUT TYPE-1	1	03-18-01-2-03-BRAKE SHOE HANGER
2	03-18-01-1-11-SCREW SPINDLE NUT TYPE-2	2	03-18-01-2-03-BRAKE SHOE HANGER
2	03-18-01-1-12-SCREW SPINDLE	2	03-18-01-2-03-BRAKE SHOE HANGER
2	03-18-01-1-13-SCREW SPINDLE HANDLE	1	03-18-01-2-04-BRAKE SHOE
4	03-18-01-1-14-FRONT-REAR HAND GRIP	6	03-18-01-2-05-BRAKE LINK BAR
1	03-18-01-1-15-FRONT STEP	2	03-18-01-2-06-BRAKE LINK BAR-1
1	03-18-01-1-15-FRONT STEP	2	03-18-01-2-07-BRAKE LINK BAR-2
1	03-18-01-1-16-FRONT STEP CROSS BAR	1	03-18-01-2-08-BRAKE LINK BAR-2
2	03-18-01-1-17-REAR STEP	1	03-18-01-2-09-HAND BRAKE COLUMN SPINDLE
1	03-18-01-1-18-AIR TANKS	1	03-18-01-RAIL-7.5inch
6	03-18-01-1-19-AXLEBOX KEEPER		
1	03-18-01-1-20-FRONT SANDBOX		
1	03-18-01-1-20-FRONT SANDBOX		
1	03-18-01-1-21-REAR SANDBOX		
1	03-18-01-1-21-REAR SANDBOX		
1	03-18-01-1-22-FRONT RAIL SCOOP		
1	03-18-01-1-22-FRONT RAIL SCOOP		
1	03-18-01-1-23-REAR RAIL SCOOP		
1	03-18-01-1-23-REAR RAIL SCOOP		
1	03-18-01-1-24-HOOD		
1	03-18-01-1-25A-HOOD DOOR-A		
1	03-18-01-1-25A-HOOD DOOR-A		
1	03-18-01-1-25B-HOOD DOOR-B		
1	03-18-01-1-25B-HOOD DOOR-B		
2	03-18-01-1-26-HOOD DOOR-C		
2	03-18-01-1-26-HOOD DOOR-C		
1	03-18-01-1-27-HOOD DOOR-D		
1	03-18-01-1-27-HOOD DOOR-D		
1	03-18-01-1-28-HOOD DOOR-E		
1	03-18-01-1-28-HOOD DOOR-E		
1	03-18-01-1-29-HOOD DOOR-F		
1	03-18-01-1-29-HOOD DOOR-F		
1	03-18-01-1-30-HOOD DOOR-G		
1	03-18-01-1-30-HOOD DOOR-G		
1	03-18-01-1-31-SIDE INSPECTION BOX		
1	03-18-01-1-31-SIDE INSPECTION BOX		
1	03-18-01-1-32-HOOD FRONT VENT DOOR		
6	03-18-01-1-33-LAMP HOLDER BRACKET		
2	03-18-01-1-34-FRONT VENT PLATE		
4	03-18-01-1-35-SIGNAL FLAG HOLDER		
1	03-18-01-1-36-EXHAUST CHIMNEY		
2	03-18-01-1-37-FRONT LADDER		
2	03-18-01-1-38-BATTERY TOOLBOX		
1	03-18-01-1-39-HOOD ROOF-A		

OTHER ABBREVIATIONS
 DP = DEEP
 DAA = DRILL AFTER ASSEMBLY
 D&TAA = DRILL AND TAP AFTER ASSEMBLY
 CF = CLOSE FIT (SIZE FOR SIZE)
 PF = PRESS FIT
 PFAA = PRESS FIT AFTER ASSEMBLY
 PCD = PITCH CIRCLE DIAMETER
 RM = REAM
 HEX = HEXAGON, 6SIDED
 CP = COMPRESSED
 KNL = KNURLED
 CSK = COUNTERSINK
 PL = PLACES
 DWL = DOWEL
 SPF = SPOTFACE
 (T)HESOP=(TAPPED)HOLES EQUALLY SPACED ON PCD
 (T)HESOC=(TAPPED)HOLES EQUALLY SPACED ON CIRCUMFERENCE
 OD = OUTSIDE DIAMETER
 ID = INSIDE DIAMETER
 [SA-xxx] = SUB ASSEMBLY-xxx

NOTES: THIS ENGINE IS BASED ON AN EARLIER PROJECT (03-18-00) WHICH WAS DRAWN UP IN OCTOBER 2019. THIS ENGINE SHOWN ON THESE DRAWINGS IS A CONVERSION FROM 3.5"/89mm TO 7.5"/190.5mm GAUGE

TITLE
DIESEL-ELECTRIC LOCOMOTIVE OF THE BRITISH RAILWAYS CLASS 08. (7.5"/190.5 GAUGE)

DRAWING CONTENTS
G.A. SIDE VIEW, REAR VIEW, ISOMETRIC VIEWS, NOTES, B.O.M.

PROJECT No 03-18-01
 JDW DRAUGHTING SERVICES
 J.A.M. DE WAAL, 12 BRIGHTWELL STREET PAPA KURA
 2110, NEW ZEALAND. PHONE: 0064 09 2988815. MOB: 0211791000 E-MAIL: dewaal@xtra.co.nz.

PROJECTION

JDWDS
 DATE MAY 2023
 SHEET: 02 OF 09

MODEL SCALE: 1:7.5
 DWG SCALE: 1:1 @A2 OR AS SHOWN
 Copyright © J.A.M. DE WAAL PAPA KURA NZ
 A2 No: 03-18-01-SHT-02

PLEASE NOTE THIS IS AN "A2" SIZE SHEET

DRAWINGS ARE FOR PERSONAL USE ONLY NOT FOR COMMERCIAL PURPOSES

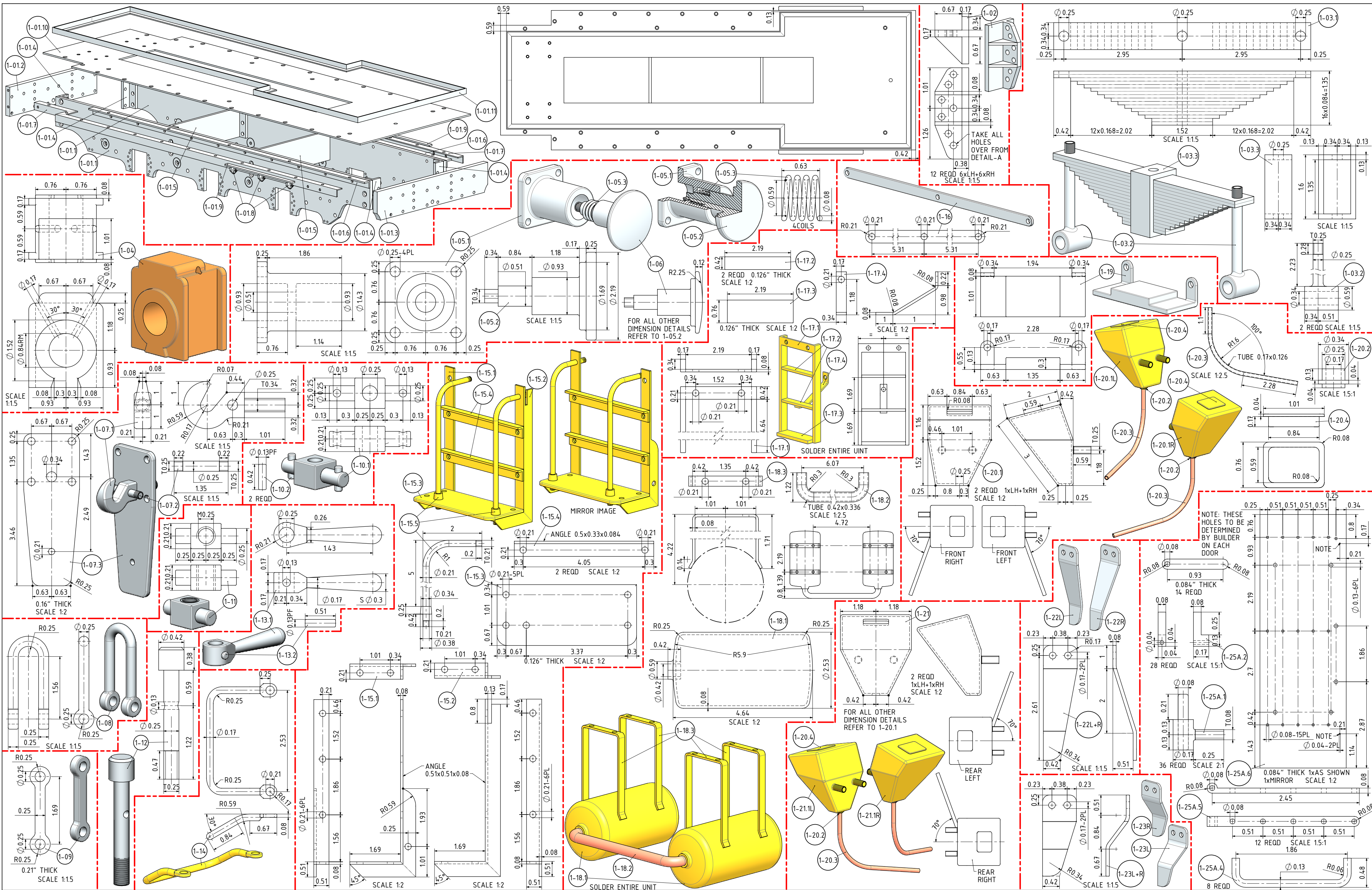

NOTES: THIS ENGINE IS BASED ON AN EARLIER PROJECT (03-18-00) WHICH WAS DRAWN UP IN OCTOBER 2019. THIS ENGINE SHOWN ON THESE DRAWINGS IS A CONVERSION FROM 3.5"/89mm TO 7.5"/190.5mm GAUGE

TITLE
DIESEL-ELECTRIC LOCOMOTIVE OF THE BRITISH RAILWAYS CLASS 08. (7.5"/190.5 GAUGE)

DRAWING CONTENTS
PARTS AND ASSEMBLIES

PROJECT No 03-18-01
 JDW DRAUGHTING SERVICES
 J.A.M. DE WAAL, 12 BRIGHTWELL STREET PAPA KURA
 2110, NEW ZEALAND. PHONE: 0064 09 2988815. MOB: 0211791000 E-MAIL: dewaal@xtra.co.nz.

PROJECTION
JDWDS
 DATE MAY 2023

MODEL SCALE: 1:7.5
 DWG SCALE: 1:1 @A2 OR AS SHOWN
 Copyright © J.A.M. DE WAAL PAPA KURA NZ
 SHEET: 04 OF 09 **A2** No: 03-18-01-SHT-04

PLEASE NOTE THIS IS AN "A2" SIZE SHEET

DRAWINGS ARE FOR PERSONAL USE ONLY NOT FOR COMMERCIAL PURPOSES

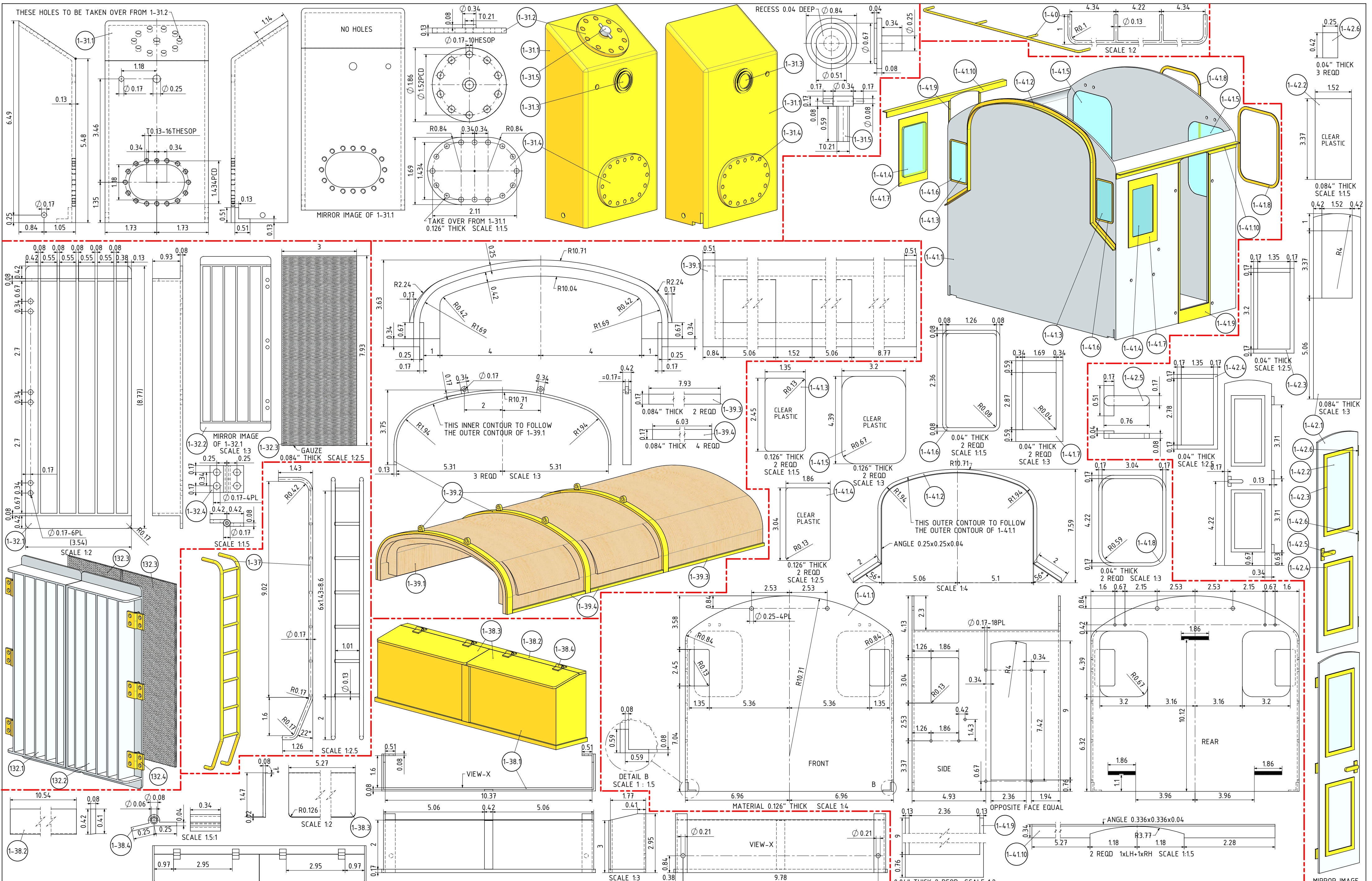

NOTES: THIS ENGINE IS BASED ON AN EARLIER PROJECT (03-18-00) WHICH WAS DRAWN UP IN OCTOBER 2019. THIS ENGINE SHOWN ON THESE DRAWINGS IS A CONVERSION FROM 3.5"/89mm TO 7.5"/190.5mm GAUGE

TITLE
DIESEL-ELECTRIC LOCOMOTIVE OF THE BRITISH RAILWAYS CLASS 08. (7.5"/190.5 GAUGE)

DRAWING CONTENTS
PARTS AND ASSEMBLIES

PROJECT No 03-18-01
 JDW DRAUGHTING SERVICES
 J.A.M. DE WAAL, 12 BRIGHTWELL STREET PAPA KURA
 2110, NEW ZEALAND. PHONE: 0064 09 2988815. MOB: 0211791000 E-MAIL: dewaal@xtra.co.nz.

PROJECTION
JDWDS
 DATE MAY 2023

MODEL SCALE: 1:7.5
 DWG SCALE: 1:1 @A2 OR AS SHOWN
 Copyright © J.A.M. DE WAAL PAPA KURA NZ
 SHEET: 06 OF 09 **A2** No: 03-18-01-SHT-06

PLEASE NOTE THIS IS AN "A2" SIZE SHEET

DRAWINGS ARE FOR PERSONAL USE ONLY NOT FOR COMMERCIAL PURPOSES

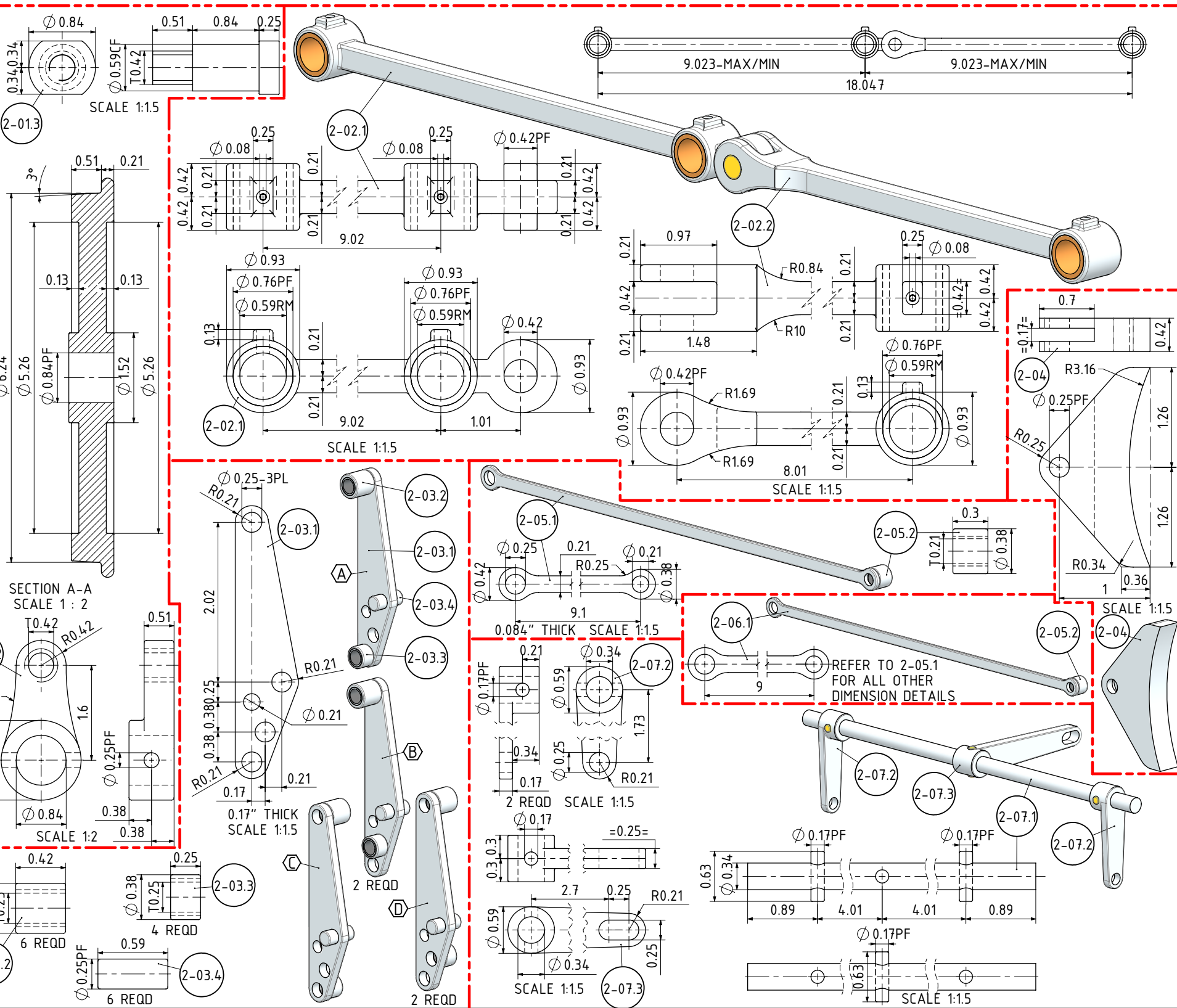
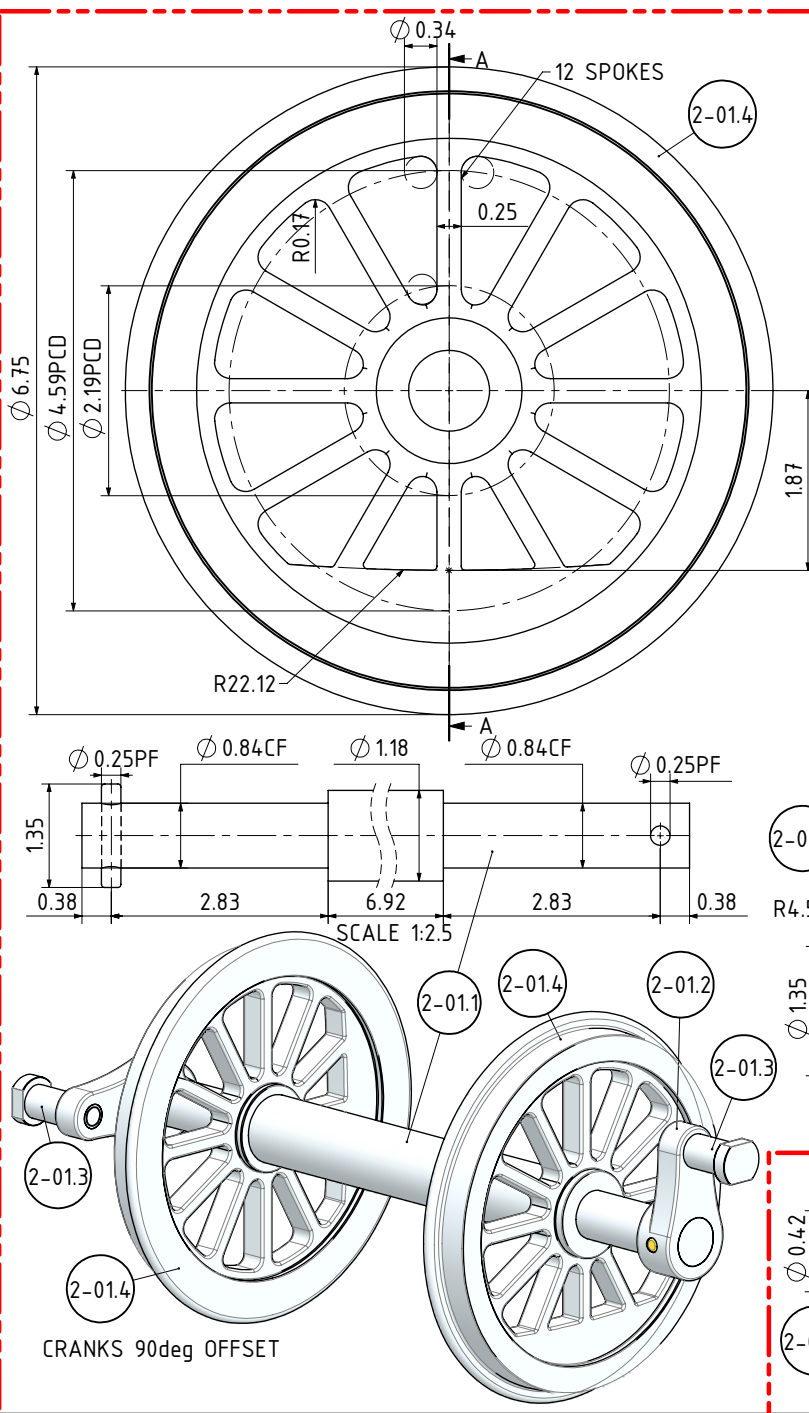
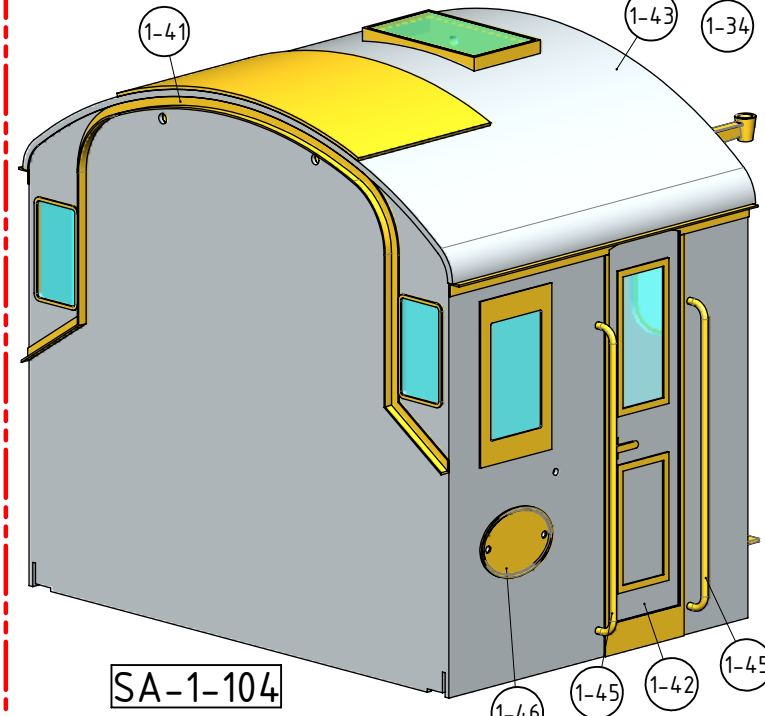
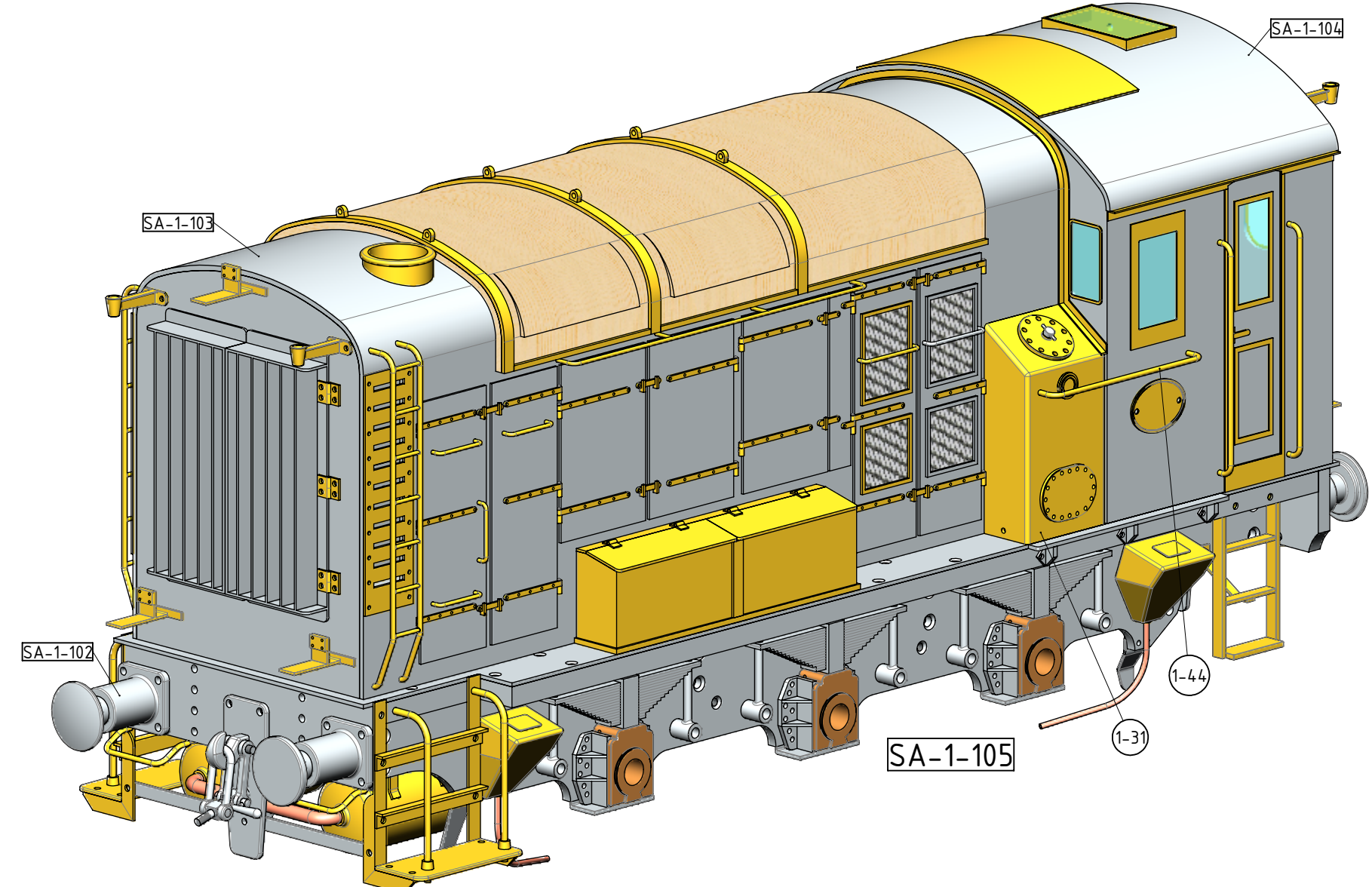
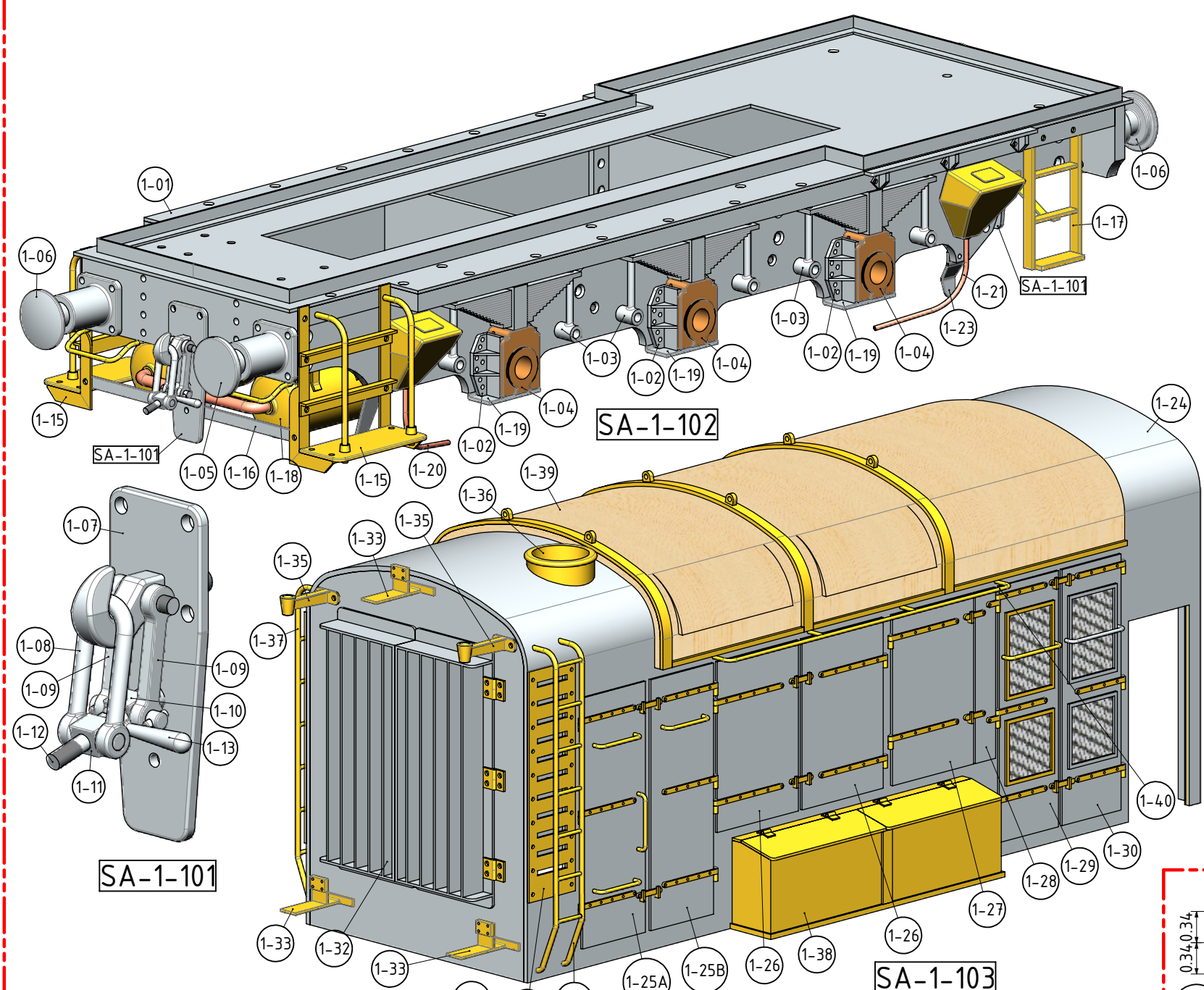
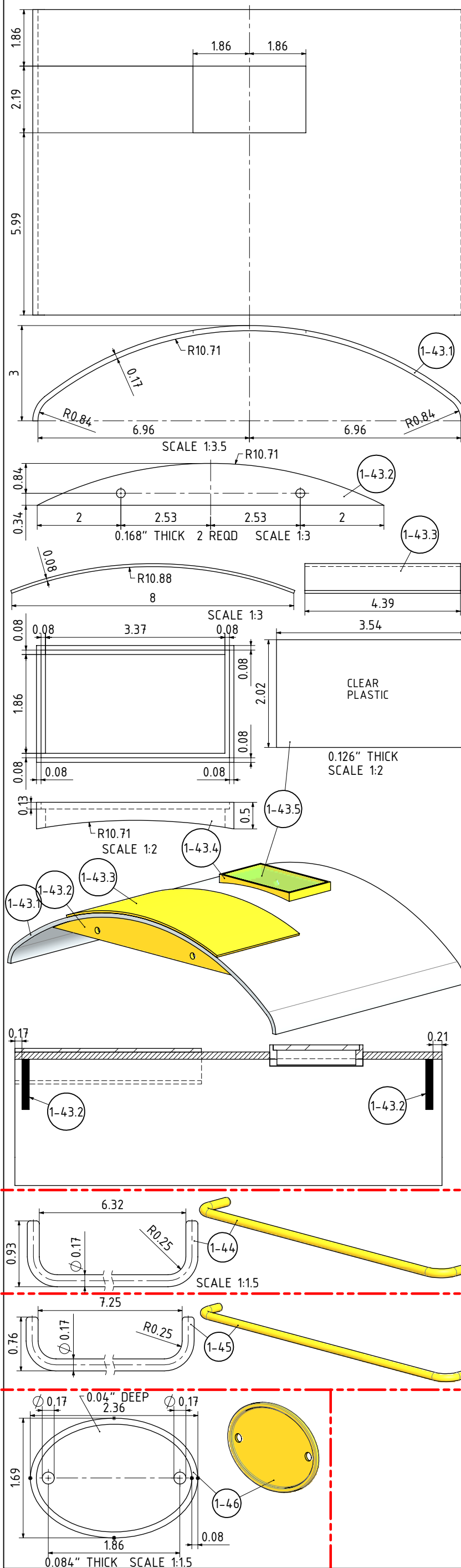

NOTES: THIS ENGINE IS BASED ON AN EARLIER PROJECT (03-18-00) WHICH WAS DRAWN UP IN OCTOBER 2019. THIS ENGINE SHOWN ON THESE DRAWINGS IS A CONVERSION FROM 3.5"/89mm TO 7.5"/190.5mm GAUGE

TITLE DIESEL-ELECTRIC LOCOMOTIVE OF THE BRITISH RAILWAYS CLASS 08. (7.5"/190.5 GAUGE)	DRAWING CONTENTS PARTS AND ASSEMBLIES	PROJECT No 03-18-01	PROJECTION 1st ANGLE	MODEL SCALE: 1:7.5
		JDW DRAUGHTING SERVICES	JDWDS	DWG SCALE: 1:1 @A2 OR AS SHOWN
		J.A.M. DE WAAL, 12 BRIGHTWELL STREET PAPA KURA 2110, NEW ZEALAND. PHONE: 0064 09 2988815. MOB: 0211791000 E-MAIL: dewaal@xtra.co.nz.	DATE MAY 2023	Copyright © J.A.M. DE WAAL PAPA KURA NZ
			SHEET: 07 OF 09	A2 No: 03-18-01-SHT-07

PLEASE NOTE THIS IS AN "A2" SIZE SHEET

DRAWINGS ARE FOR PERSONAL USE ONLY NOT FOR COMMERCIAL PURPOSES

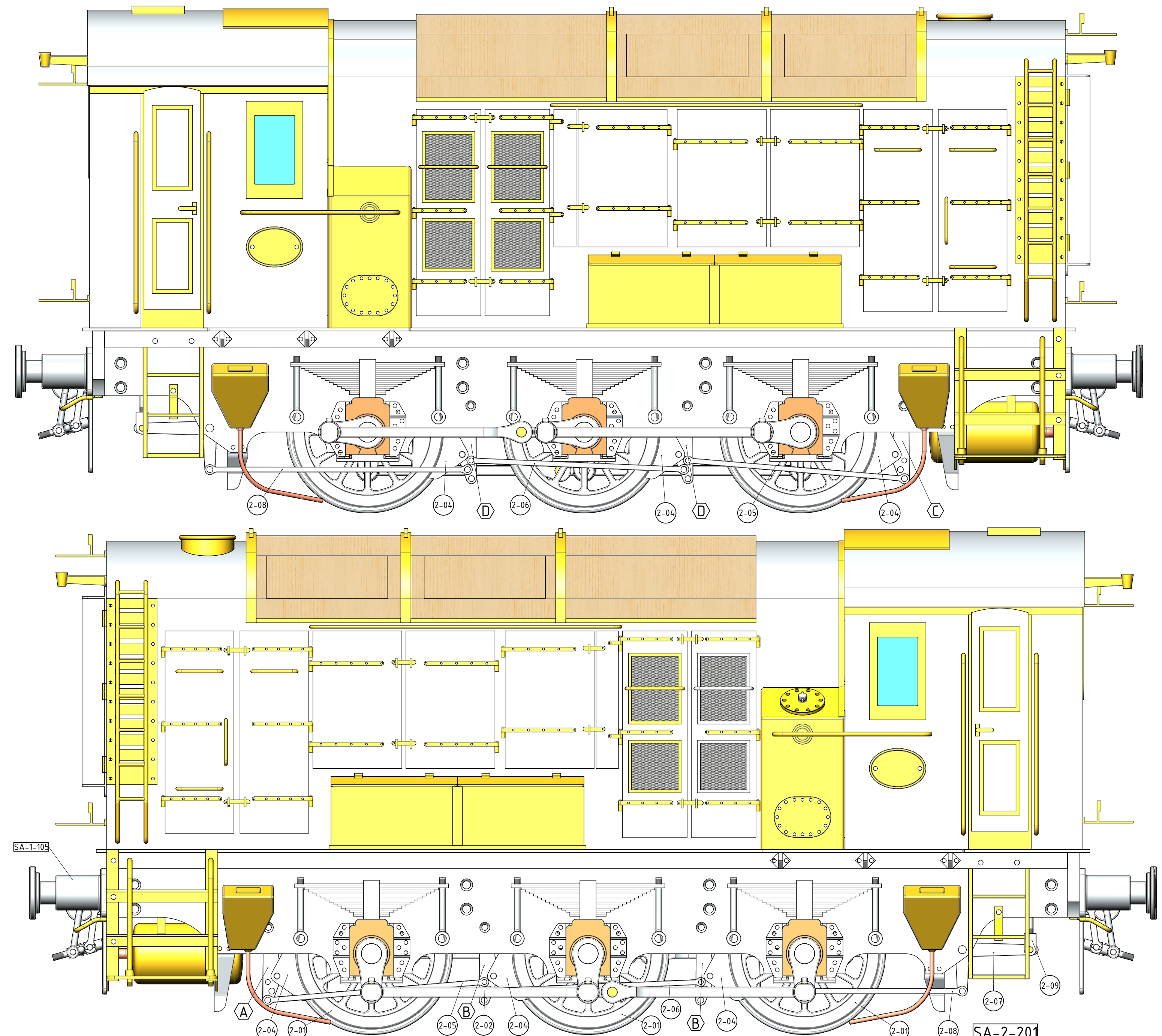
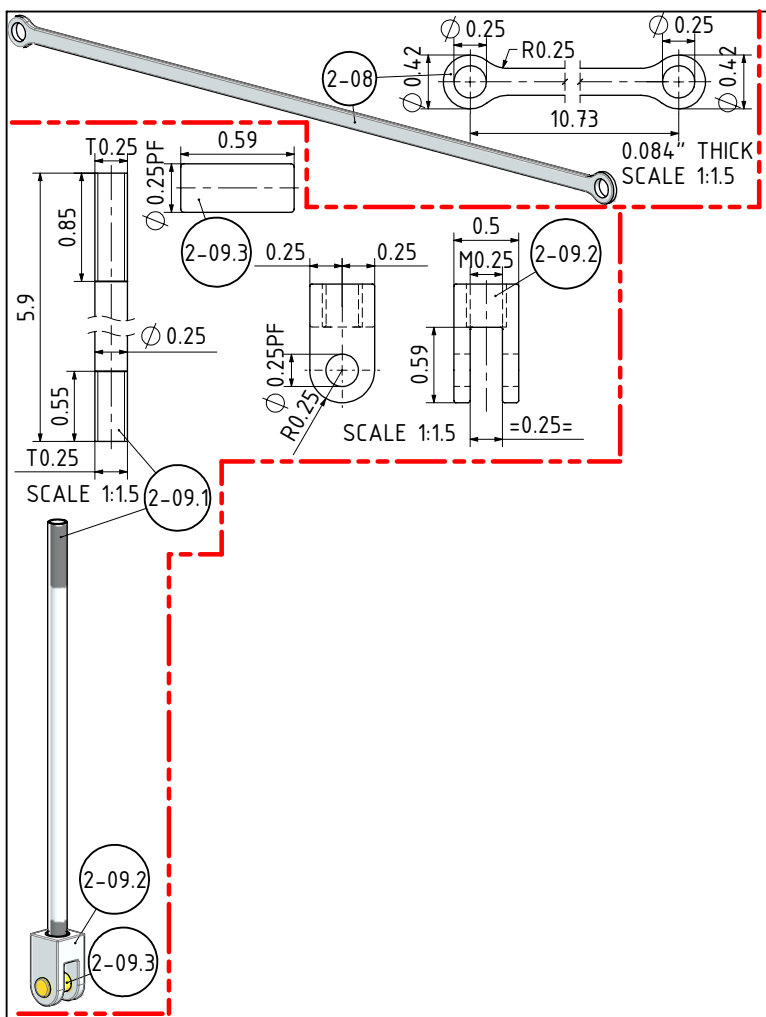

NOTES: THIS ENGINE IS BASED ON AN EARLIER PROJECT (03-18-00) WHICH WAS DRAWN UP IN OCTOBER 2019. THIS ENGINE SHOWN ON THESE DRAWINGS IS A CONVERSION FROM 3.5"/89mm TO 7.5"/190.5mm GAUGE

TITLE
DIESEL-ELECTRIC LOCOMOTIVE OF THE BRITISH RAILWAYS CLASS 08. (7.5"/190.5 GAUGE)

DRAWING CONTENTS
PARTS AND ASSEMBLIES

PROJECT No 03-18-01
 JDW DRAUGHTING SERVICES
 J.A.M. DE WAAL, 12 BRIGHTWELL STREET PAKAPURA
 2110, NEW ZEALAND. PHONE: 0064 09 2988815. MOB: 0211791000 E-MAIL: dewaal@xtra.co.nz.

PROJECTION
JDWDS
 DATE MAY 2023
 SHEET: 08 OF 09

MODEL SCALE: 1:7.5
 DWG SCALE: 1:1 @A2 OR AS SHOWN
 Copyright © J.A.M. DE WAAL PAKAPURA NZ
 A2 No: 03-18-01-SHT-08

PLEASE NOTE THIS IS AN "A2" SIZE SHEET

DRAWINGS ARE FOR PERSONAL USE ONLY NOT FOR COMMERCIAL PURPOSES



NOTES: THIS ENGINE IS BASED ON AN EARLIER PROJECT (03-18-00) WHICH WAS DRAWN UP IN OCTOBER 2019. THIS ENGINE SHOWN ON THESE DRAWINGS IS A CONVERSION FROM 3.5"/89mm TO 7.5"/190.5mm GAUGE

TITLE
DIESEL-ELECTRIC LOCOMOTIVE OF THE BRITISH RAILWAYS CLASS 08. (7.5"/190.5 GAUGE)

DRAWING CONTENTS
RENDERED PICTURE

PROJECT No 03-18-01

JDW DRAUGHTING SERVICES
 J.A.M. DE WAAL, 12 BRIGHTWELL STREET PAPAURA
 2110, NEW ZEALAND. PHONE: 0064 09 2988815. MOB:
 0211791000 E-MAIL: dewaal@xtra.co.nz.

PROJECTION

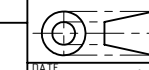

JDWDS

DATE MAY 2023

MODEL SCALE: 1:7.5

DWG SCALE: 1:1 @A2 OR AS SHOWN

Copyright © J.A.M. DE WAAL PAPAURA NZ

SHEET: 09 OF 09

A2 No: 03-18-01-SHT-09

PLEASE NOTE THIS IS AN "A2" SIZE SHEET

DRAWINGS ARE FOR PERSONAL USE ONLY NOT FOR COMMERCIAL PURPOSES